

Maintenance instruction

This maintenance instruction is a step-by-step instruction for service and maintenance on Stafsjö's knife gate valves MV and MP. The instruction shall be available for persons responsible for service and maintenance on Stafsjö's knife gate valves. The following procedures are described:

- A – Change of seat**
- B – Change of box packing**
- C – Change of box packing when the valve is installed in a system**
- D – Torque for gland nuts**
- E – Torque for MV valve body screw joint reinforcement**
- F – Change from hand wheel (HW) to pneumatic cylinder**
- G – Change of gate, guiding pads and gate support**
- H – ATEX, change of spring**



For more detailed information on technical data of valves, actuators or accessories, please see data sheets on www.stafsjo.com, or contact Stafsjö or your local representative.

Each knife gate valve is identified with a label containing the article number and serial number. When in contact with Stafsjö or your local representative, please have these numbers available.

Stafsjö Valves AB does not accept any responsibility for the product if service and maintenance on the knife gate valve is not performed according to this instruction. Nor does Stafsjö Valves AB accept any responsibility of the product if any significant change has been done to the product.

Spare parts

Recommended spare parts are described in spare part data sheets for each knife gate valve type on www.stafsjo.com. Stafsjö recommends the customer to keep one set of spare parts for each valve type and size in store.

Spare parts can be ordered from Stafsjö or your local representative. Spare part data sheets and addresses are available on www.stafsjo.com.

Safety information

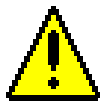

No work is allowed on the knife gate valve when the system is pressurised or the actuator is connected. The system must be free from pressure and empty. Actuator and accessories must be disconnected before any work is commenced.

All gate guards must be installed after finished maintenance on the knife gate valve.

All specifications subject to change without notice.

Main components in the Stafsjö knife gate valve MV/MP

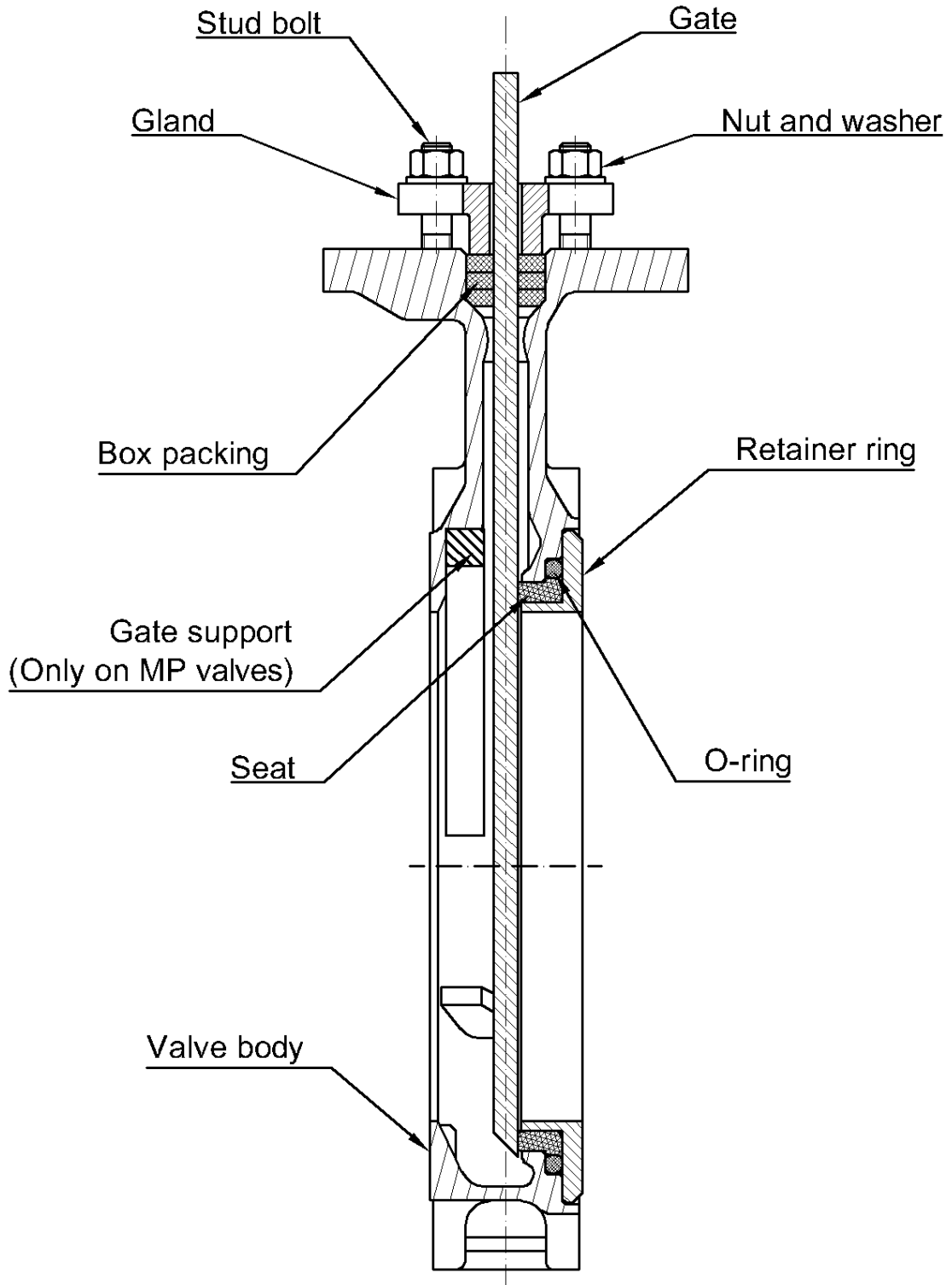

Figure 1 Main components

Part list of the Stafsjö knife gate MV

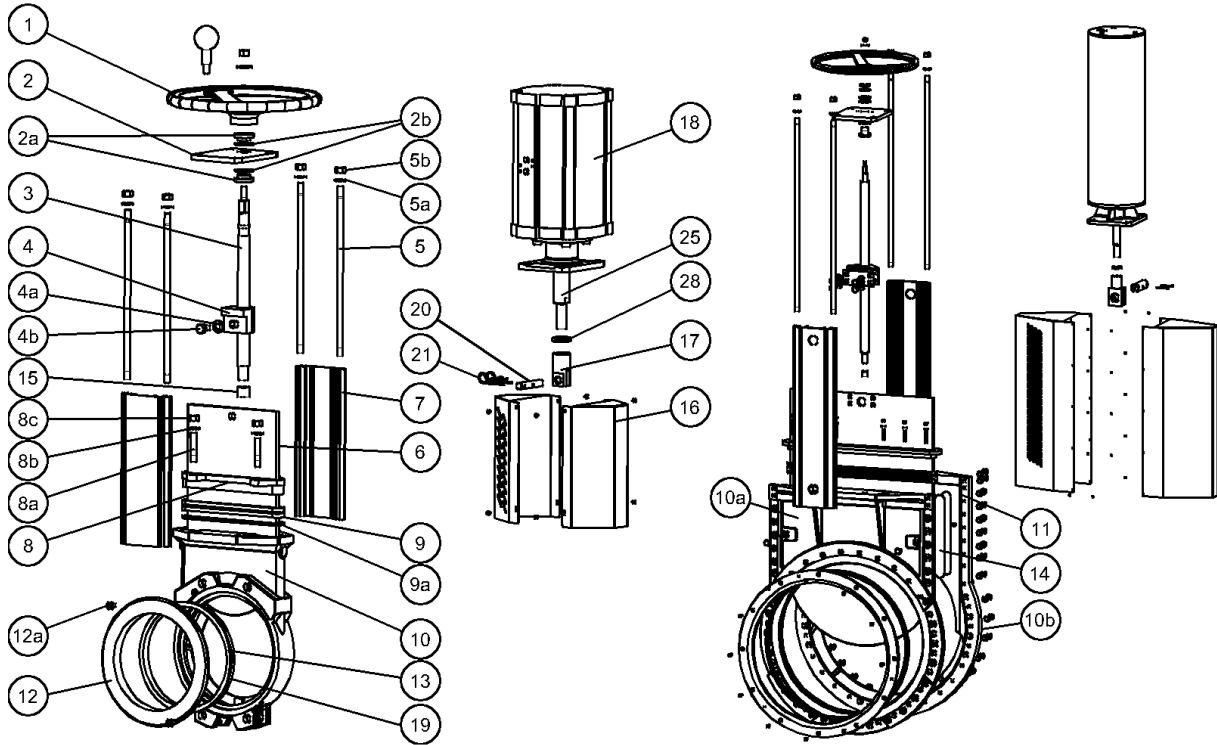

Figure 2 Part list of MV, numbering also applies to MP valves in similar manner

Part list

Pos	Part
1	Hand wheel
2	Yoke
2a	Bearing
2b	Slide washer
3	Stem
4	Stem nut
4a	Washer
4b	Screw
5	Tie rod

Pos	Part
5a	Washer
5b	Nut
6	Gate
7	Beam
8	Gland
8a	Stud bolt
8b	Washer
8c	Nut
9	Box packing

Pos	Part
9a	Box bottom support
10(a/b)	Valve body
11	Body gasket
12	Retainer ring
12a	Locking screw
13	Seat
14	Guiding pads
15	Bushing
16	Gate guard

Pos	Part
17	Cate clevis
18	Cylinder
19	O-ring
20	Clevis pin
21	Split pin
25	Piston rod
28	Locking nut

Service and maintenance

See figure 1-2 for identification of parts on the MV and MP valve. Parts differ depending on the valve size. Please contact Stafsjö Valves AB or your local representative if you have any questions.

For more information on installation and operation of the knife gate valve and pneumatic cylinder, please see Operating instruction for knife gate valves and pneumatic cylinders on www.stafsjo.com or contact Stafsjö Valves AB or your local representative.

Stafsjö Valves AB offers the customer service and maintenance of Stafsjö knife gate valves, either in the customer's plant or at the Stafsjö workshop. Please contact Stafsjö Valves AB or your local representative for more information.

For procedures A, B, E, F and G the knife gate valve must not be installed in a system.

A – Change of seat

Place the valve horizontally on a work bench for an easier change of seats.

1. Disassemble the valve from the pipe system.
2. Open the valve with the mounted actuator.
3. Disconnect the supply for actuator.
4. Remove the retainer ring (12) by unscrewing the screws (12a) it is fastened with.
5. Lift of the Retainer ring (12). If the retainer ring is stuck, use a screw driver or similar tool and bend carefully between the retainer ring and the valve body in several places around the bore until the ring is loose.
6. Check the gate (6) for damages such as dents and scratches. If the gate is damaged it can wear out the box packing (9) and the seat (13), causing leakage. Stafsjö recommends changing the gate if it is damaged to ensure the function of the valve.
7. Clean the area of the seat and the valve body.
8. Install a new seat (13) on the retainer ring (12) and place the retainer ring in the valve body (10). For PTFE or metal seat, O-rings (19) must also be installed, see figure 3. Lubricate the seat and the O-rings with a synthetic lubricator to make the installation easier.
9. Lock the retainer ring (12) in place with the screws (12a). The screws function is only to hold the retainer ring in place. The function of the retainer ring will take effect when the valve is mounted between pipe flanges.
10. Install the valve in closed position in to the system according to the operating instruction.
11. Operate the valve a few times before the system is pressurised.

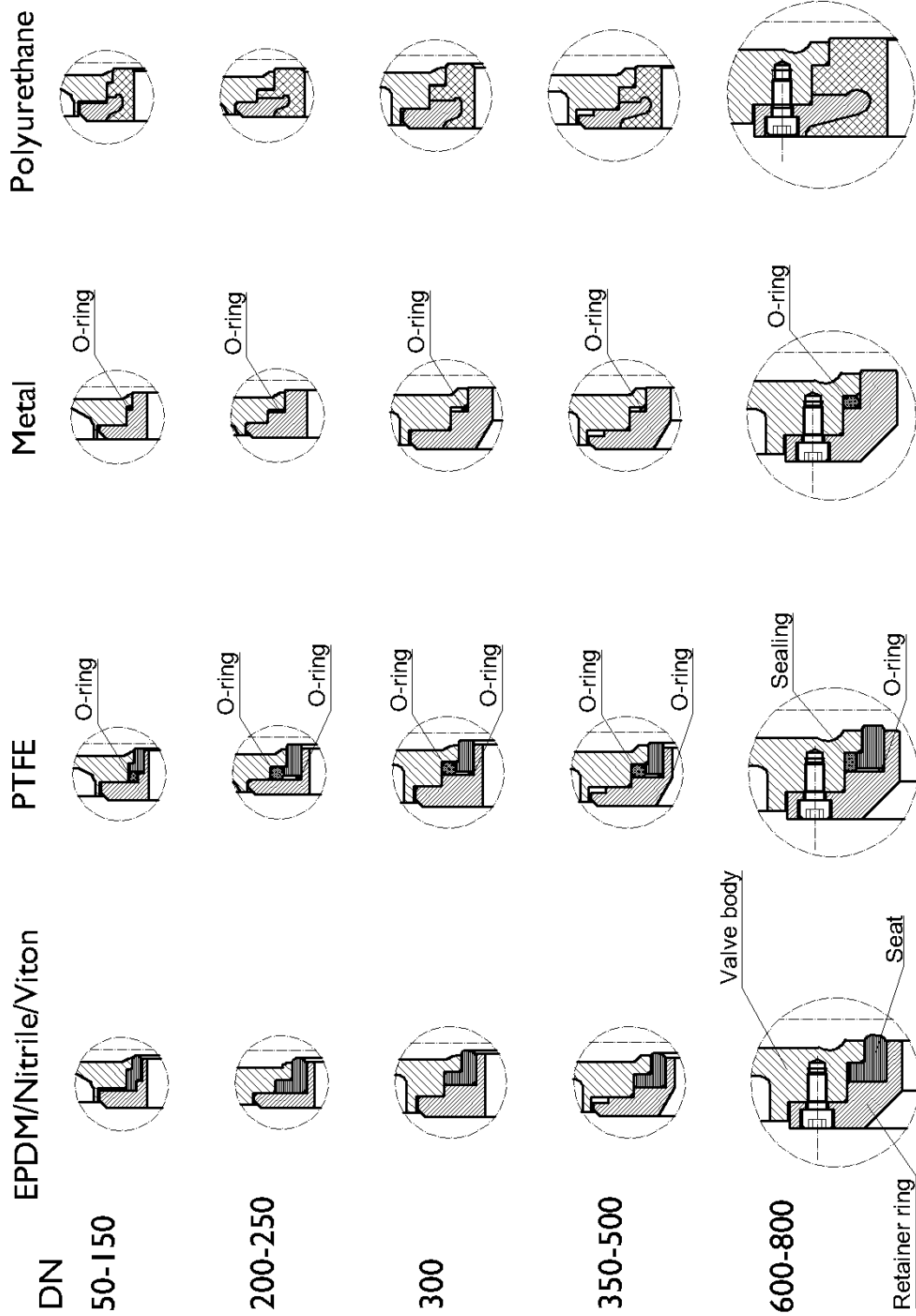

Figure 3 Seat and O-rings

B – Change of box packing

Place the valve upright in for example a screw vice to simplify changing the gate and box packing. Large valves shall be placed on a horizontal work bench.

1. Close the valve.
2. Demount the actuator and top by:

Pneumatic cylinder (18)

1. Disconnect the air connections so that the cylinder (18) is depressurised.
2. Remove the gate guards (16).
3. Demount the split pins (21) and clevis pin (20).
4. Loosen the nuts (5b) keeping the cylinder in place.
5. Lift off the cylinder (18).
6. Demount the beam (7) and tie rods (5) from the valve

Hand wheel (1)

1. Demount the hand wheel (1).
2. Loosen the nuts (5b).
3. Lift off the bearing (2c), bearing washer (2b), yoke (2), bearing washer (2b) and bearing (2a) from the stem (3).
4. Demount the beams (7) and tie rods (5).
5. Loosen the screw (4b) from the stem nut (4) and gate (6).
6. Lift off the stem (3) and stem nut (4).

3. Loosen the nuts (8c) on the gland (8).
4. Lift of the gland (8) from the stud bolts (8a).
5. Remove the box packing braid (9) and if any, box bottom support (9a).
6. Clean the box from residues.
7. Check the gate (6) visually for damages such as dents and scrapes. If the gate is damaged it can wear out the box packing (9) and the seat (13), causing leakage. Stafsjö recommends changing the gate if it is damaged to ensure the function of the valve.
8. If any, check that the guide pads/gate support (14) in the valve body are not worn out and in place.
9. If any, check the box bottom support (9a) for damages. If the box bottom (9a) is damaged Stafsjö recommends changing it. Place the box bottom (9a), in the valve body (10).
10. Check that the gate chamfer is set against the cams in the bottom of the valve body, see figure 1.
11. Begin assembling the first braid (9) on one of the long sides of the gate (6). Use a blunt tool in plastic or wood and a hammer to push the braid into the box. Where the braid ends meet, check that the short ends are opposite each other, not on top of each other. It is important to push the first braid evenly into the bottom of the box. The joint of next braid must be placed on the opposite long side of the joint of the previous braid.
12. Place the gland (8) on the stud bolts (8a).
13. Add the washers (8b) and nuts (8c).
14. Put force on the gland (8) by tightening the nuts (8c) gradually and crosswise. The box packing must be equally compressed all around. Recommended torque for gland nuts, see chapter D.

15. The gland (8) must put uniform force on the box packing (9) and be in level with the top of the valve body (10).
16. The gland (8) must also be in line with the gate (6) with the same distance between the gland and the gate all around. Check that there is no metal contact between the gland (8) and the gate (6).
17. Assemble the other components in reversed order, step 2.
18. Function test the knife gate valve.
19. Reinstall the valve in the system according to the operating instruction.
20. Operate the valve a few times before the system is pressurised.

Note:

The box packing may start to leak when the system is pressurised and the temperature increases. This is caused by the box packing material which is a soft material that moves depending on pressure and temperature and when the valve is operated. If the box packing is leaking, tighten the gland nuts (8c) gradually and crosswise according to chapter D.

C – Change of box packing when the valve is installed in a system



No work is allowed on the Stafsjö knife gate valve when the system is pressurized or the automatic actuator is connected. The system must be empty and free from pressure before work begins. The actuator and accessories must be disconnected before work begins.

Work on the knife gate valve when the system is under pressure can cause damages on persons and equipment.

Check that the system is free from pressure by:

- **Observing the pressure measurement on the system**
- **Opening the drain on the pipe**

When the system is free from pressure and empty:

1. Open the valve making a distance between the gland (8) and the gate clevis (17) or stem nut (4).
2. Loosen the nuts (8c) on the gland (8).
3. Disconnect the supply for actuator.
4. Lift the gland (8) and connect it to the gate clevis (17) or stem nut (4) with a wire to be able to reach into the box packing (9).
5. Remove the box packing braids (9) and if any, box bottom support (9a).
6. Clean the box from residues.
7. Check the gate (6) visually for damages such as dents and scrapes. If the gate is damaged it can wear out the box packing (9) and the seat (13), causing leakage. Stafsjö recommends changing the gate if it is damaged to ensure the function of the valve.
8. If any, check the box bottom support (9a) for damages. If the box bottom (9a) is damaged Stafsjö recommends changing it. Place the box bottom (9a), in the valve body (10).
9. Begin assembling the first braid (9) on one of the long sides of the gate (6). Use a blunt tool in plastic or wood and a hammer to push the braid into the box. Where the braid ends meet, check that the short ends are opposite each other, not on top of each

other. It is important to push the first braid evenly into the bottom of the box. The joint of next braid must be placed on the opposite long side of the joint of the previous braid.

10. Let down the gland (**8**) on the stud bolts (**8a**).
11. Add the washers (**8b**) and nuts (**8c**).
12. Put force on the gland (**8**) by tightening the nuts (**8c**) gradually and crosswise. The box packing must be equally compressed all around. Recommended torque for gland nuts, see chapter D.
13. The gland (**8**) must put uniform force on the box packing (**9**) and be in level with the top of the valve body (**10**).
14. The gland (**8**) must also be in line with the gate (**6**) with the same distance between the gland and the gate all around. Check that there is no metal contact between the gland (**8**) and the gate (**6**).
15. Operate the valve a few times before the system is pressurised.

Note:

The box packing may start to leak when the system is pressurised and the temperature increases. This is caused by the box packing which is a soft material that moves depending on pressure and temperature and when the valve is operated. If the box packing is leaking, tighten the gland nuts (**8c**) gradually and crosswise according to chapter D.

D – Torque for gland nuts

The torque T_G in the table below is a recommended value for tightening the gland nuts (**8c**) when a new box packing has been installed and during operation if the box packing is leaking.

MV/MP	T_G	
	Nm	lbf x ft
DN		
50-80	20	15
100-150	25	18
200-300	30	22
350-	35	26

If the gland nuts are pulled to hard, it shortens the lifetime of the box packing and the force needed to operate the valve will increase and the valve function will be affected.

The box packing may leak because it is made of a soft material that moves depending on pressure and temperature and when the valve is operated. If the box packing is leaking, tighten the gland nuts (**8c**). Each nut shall be tightened gradually and crosswise until the leakage stops. See figure 4.

Check that the gland (**8**) is level to the top of the valve body (**10**). Check that there is no metal contact between the gland (**8**) and the gate (**6**).

E – Torque for MV valve body screw joint reinforcement

The torque T_s in the table below is a recommended value for tightening the screw joint reinforcement between the two MV (DN900-) valve body sides.

MV knife gate DN	Screw joint reinforcement Sd mm	Torque T_s Nm	Torque T_s lbf x ft
900	M16	190	140
1000	M16	190	140
1200	M20	350	258
1400	M20	350	258

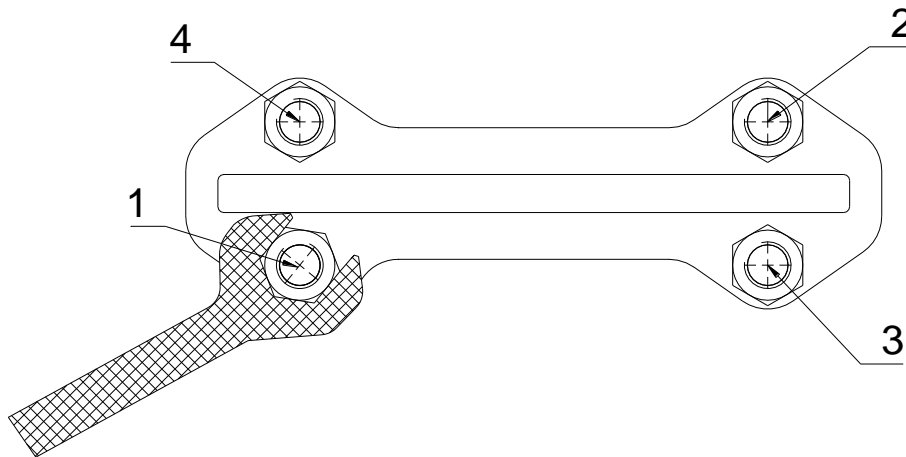

Figure 4 Crosswise tightening of nuts.

F – Change from hand wheel (HW) to pneumatic cylinder

To be able to adjust the cylinder stroke, the pneumatic cylinder must be installed on the knife gate valve when the valve is not installed in a system.

Large pneumatic cylinders installed horizontally must be supported to not cause tensions in the valve which might affect the valve tightness and ability to maneuver.

1. Close the valve completely.
2. Demount the hand wheel actuator.

Hand wheel

1. Demount the hand wheel (1).
2. Loosen the nuts (5b) on the tie rods (5).
3. Lift off the bearing washer (2b), yoke (2) and bearing (2a) from the stem (3).
4. Lift off the beams (7).
5. Loosen the screw (4b) from the stem nut (4) and gate (6).
6. Lift off the stem (3) and stem nut (4).

3. Screw the locking nut **(28)** and the gate clevis **(17)** halfway on to the cylinder piston rod **(25)**.
4. Assemble new beams **(7)** with holes on the tie rods **(5)**. The holes on the beam are placed on different distances from the short side of the beam. The side of the beam with the longest distance between the hole and the short side shall be placed against the top of the valve body **(10)**.
5. Mount the cylinder **(18)** on top of the beams and fixate with washers **(5a)** and nuts **(5b)**.
6. Attach the gate clevis **(17)** to the gate with the clevis pin **(20)** and the split pins **(21)**.
7. Open the valve completely by gently operating the pneumatic cylinder **(18)**. In this position, the bottom edge of the gate **(6)** should be in line with the retainer ring edge **(12)**. If it is not, close the valve, demount the split pins **(21)** and clevis pin **(20)** and adjust the gate clevis **(17)** on the piston rod **(25)** until the gate edge and retainer ring edge are in line with each other when the valve is open.
8. Lock the gate clevis **(17)** with the locking nut **(28)**.
9. Function test the knife gate valve.
10. Assemble the gate guards **(16)**.
11. Install the valve in the system according to the operating instruction.
12. Operate the valve a few times before the system is pressurised.

G – Change of gate, guiding pads and gate support

To be able to change gate, guiding pads **(14)** or gate support **(14)** on MV/MP knife gate valve, must the valve not be installed in the system. Place the valve horizontally on a work bench.

Please contact Stafsjö Valves AB or your local representative if you have any questions.

The following instructions describe change of guide strips, gate and body gasket.

1. Remove the actuator **(18/1)** and the box packing **(9)**, see chapter B.
2. Remove the retainer ring **(12)** and seat **(13)**. See chapter A.
3. Remove the gate **(6)** and check for damages such as dents and scrapes. If the gate is damaged it can wear out the box packing **(9)** and the seat **(13)**, causing leakage. Stafsjö recommends changing the gate if it is damaged to ensure the function of the valve.
4. Clean the valve body **(10)** and gate **(6)** from residues.
5. Check and if necessary replace the guiding pads/gate support **(14)** in the valve body **(10)**. If the valve body **(10)** is bolted, divide the two valve body sides by unscrewing the screw joint reinforcement. Otherwise skip to step 12.
6. If any, mount the other side of the valve body **(10)** and guide the valve body sides with screws in the corners of the valve body. Use for example washers of 1-2 mm to keep the valve body sides apart to be able to insert the body gasket **(11)**.
7. If any, insert the new body gasket **(11)** in the grooves of the valve body. The body gasket must be sticking out 5-10 mm from the bottom of the box on each side.
8. Remove the washers separating the valve body sides.
9. Tighten the screws crosswise and gradually until they are fully tightened. Recommended torque values are described in chapter E.
10. Grind off the body gasket 0.5-1 mm from the bottom of the box.
11. Seal the groove opening with a flexible sealant.

12. Place the gate **(6)** in the valve body **(10)**. Check that the gate is placed correctly with the gate chamfer on the cams in the bottom of the valve body, see figure 1.
13. Assemble the other components in reversed order. See step 1-2.
14. Install the valve in the system according to the operating instruction.
15. Operate the valve a few times before the system is pressurised.

H – ATEX, change of spring

Valves with ATEX classification have the gate **(6)** connected to the rest of the valve by a spring **(66)** attached to a gland stud bolt **(8a)**. An earth cable **(69)** is connected to a stud bolt **(8a)** to make sure the valve is grounded in all situations. For procedures B, C and G where the gland **(8)** or the gate **(6)** need to be removed in an ATEX valve, must also the spring **(66)** and earth cable **(69)** be removed. See figure 5 for ATEX parts list. Note: The appearance of the spring holders **(67/68)** in the knife gate valve differs depending on the valve size. There are different categories of ATEX, the number of springs and earth cables differ between categories.

1. Close the gate **(6)**.
2. Disconnect the supply for actuator.
3. Before disassembling, document how the parts are installed to ensure proper assembling.
4. Remove the earth cable **(69)** by unscrewing the top nut **(8c)** on the stud bolt **(8a)**.
5. Unscrew the spring holders **(67, 68)** from the gate **(6)** and stud bolt **(8a)**.
6. Remove the spring **(66)** and check for any defects. For security reasons Stafsjö recommends changing the spring every 10 000 strokes to ensure the function of the valve.
7. Assemble the spring holders **(67, 68)** with the spring **(66)**.
8. Assemble the spring holder **(67)** on the longer stud bolt **(8a)**. Make sure to use low profile nuts **(8c)** to fasten the spring holder **(67)**. Screw a low profile nut **(8c)** on the stud bolt, place the spring holder **(67)** and use another low profile nut **(8c)** to fix the spring holder in place.
9. Assemble the other spring holder **(68)** on the gate **(6)** with screws, washers and nuts **(68a, b, c)**.
10. Assemble the earth cable **(69)** by fixing it between two low profile nuts **(8c)** on the stud bolt **(8a)** opposite of the spring.
11. Function test the knife gate valve by full open/close stroke. Check that the spring **(66)** can operate freely.

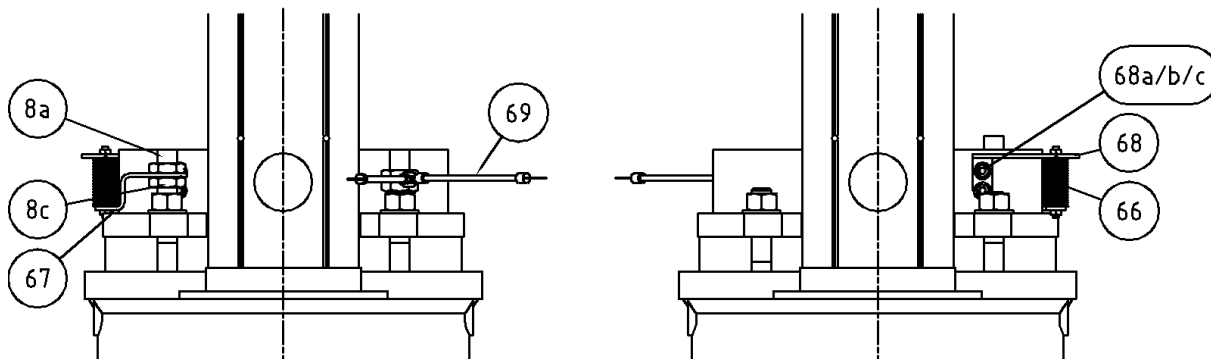

Figure 5 Parts list for an ATEX valve

Parts list

Pos	Part
8a	Stud bolt
8c	Nut
66	Spring
67	Spring holder
68	Spring holder

Pos	Part
68a	Screw
68b	Washer
68c	Nut
69	Earth cable