

## Downstream pressure controlled regulator without auxiliary power, Model T 6

The task of pressure reducing valves for steam is to reduce a varying or constant upstream pressure of the steam to a constant reduced pressure (back pressure) which is independent of the upstream pressure.

Pressure reduction occurs by throttling the free cross-section between the seat and the cone. Any change in pressure on the downstream pressure side is immediately converted into a displacement of the valve cone. With zero load, i. e. when the load on the downstream pressure side is zero, the valve does not seal tightly.

With the Model T 6 the max. reduction ratio of 25 : 1 should not be exceeded, the lowest downstream pressure is 1 bar.

### Mass flow :

A mass flow graph for saturated steam is given on page 4. A prerequisite is critical flow, i. e. low pressure  $p_2$  (bar<sub>abs</sub>) / high pressure  $p_1$  (bar<sub>abs</sub>) = 0.577.

With non-critical flow the indicated forward flow must be multiplied with an appropriate multiplier.

$\frac{p_2}{p_1}$ bar <sub>abs</sub>	0.60	0.70	0.80	0.85	0.90
Multiplier	1.00	0.96	0.85	0.77	0.65

If the mass flow table (saturated steam) is to be used for superheated steam, then the weight of superheated steam present (kg/h) must be multiplied with the factor :

$$\sqrt{\frac{V_H}{V_S}} \text{ (Table, page 2)}$$

**Important note :** After pressure reduction (throttling) saturated steam becomes superheated steam.  
(Upstream pressure  $\leq$  32 bar)

For enquiries and orders we would like the following details :

Upstream pressure  
Downstream pressure (reduced pressure)  
Temperature of the steam  
(if not saturated steam)  
Quantity of steam

### Installation notes :

A strainer should normally be installed in the upstream pressure line.

Dirt between the seat and cone prevents proper sealing for zero consumption, particularly with steam due to the narrow gaps between the seat and cone. It is practicable to install a shut-off valve on the upstream pressure side.

### IMPORTANT!

**It is essential to install a safety valve on the exit site to protect the loads.**

**With compressible media the volume given by the flow on the upstream pressure side and the reduction ratio must be able to be passed. (Take into account superheating for volumes on the reduced pressure side).**

**The pressure reducing valve must be fitted as closely as possible to the loads. Long pipes on the reduced pressure side impair the regulation.**

It must be ensured that the **cooling cylinder is not thermally insulated**, because otherwise no condensate can form in the control unit.

The valve must for this reason be installed **horizontally** in the piping and the **cooling cylinder must hang downwards**.

**Mounting direction :**

The arrow cast on the valve housing must point to the reduced pressure side.

The steam must enter from below the cone. The pipe carrying the steam in front of and behind the reducing valve must be kept free from condensate.

It has been found practicable to implement the approach and tail distances straight (10 x pipe diameter) so that, where possible, no turbulences, which may affect pressure regulation, occur in front of and behind the pressure reducing valve.

Setting ranges of the downstream pressure and corresponding spring-no.

bar from- to	15-40	50	DN 65	80	100
- 0.40	-	-	29	-	-
0.40 - 0.63	7	29	28	39	38
0.63 - 1.00	9	28	27	38	37
1.00 - 1.60	8	27	26	37	36
1.60 - 2.50	7	26	25	36	35
2.50 - 4.00	6	25	24	35	34
4.00 - 6.30	5	24	23	34	33
6.30 - 10.00	4	23	22	33	32
10.0 - 16.0	3	22	21	32	32+Int.spr.
16.0 - 23.0	-	-	21+Int.spr.	-	-
16.0 - 25.0	2	21	-	32+Int.spr.	-
25.0 - 35.0	-	21+Int.spr.	-	-	-
25.0 - 40.0	1	-	-	-	-

Lower and higher downstream pressures than those specified need special control units.

Versions : T6 in grey cast iron\*      DIN PN16  
                   in cast steel\*                DIN PN40  
                   in cast alloy steel            DIN PN40

- DN 125-200 special dimension drawing

\* Seat, cone and spindle in stainless steel

### Superheat temperature °C

bar	°C	120	160	170	180	200	220	240	260	280	300	320	350	400	450	500
2			1,04	1,05	1,07	1,09	1,11	1,14	1,16	1,18	1,20	1,22	1,25	1,30	1,35	1,40
4			1,03	1,03	1,04	1,07	1,09	1,12	1,14	1,16	1,18	1,20	1,24	1,29	1,34	1,39
5				1,02	1,03	1,06	1,08	1,11	1,13	1,15	1,17	1,19	1,23	1,28	1,33	1,38
7	DIN PN16				1,02	1,04	1,07	1,09	1,12	1,14	1,16	1,18	1,22	1,26	1,31	1,36
10	GG 20					1,03	1,06	1,08	1,10	1,13	1,15	1,17	1,21	1,25	1,30	1,35
13						1,03	1,05	1,07	1,09	1,11	1,14	1,16	1,20	1,24	1,29	1,34
16							1,04	1,06	1,08	1,10	1,14	1,17	1,19	1,24	1,29	1,34
20	DIN PN40						1,01	1,04	1,07	1,10	1,12	1,14	1,18	1,23	1,28	1,33
25	GS-C25							1,03	1,06	1,09	1,11	1,13	1,17	1,22	1,27	1,32
32								1,01	1,04	1,07	1,10	1,13	1,16	1,22	1,27	1,32
40									1,02	1,06	1,11	1,12	1,16	1,22	1,27	1,32
50	DIN PN100									1,03	1,07	1,10	1,15	1,22	1,27	1,32
64	GS-17CrMo55										1,03	1,07	1,12	1,21	1,26	1,31
80											1,01	1,06	1,12	1,21	1,26	1,31
100												1,03	1,11	1,21	1,28	1,35
120	DIN PN160												1,10	1,22	1,30	1,38
140	GS-17CrMo55												1,07	1,22	1,32	1,42
160													1,05	1,24	1,35	1,46

This brochure contains only a part of our product range. Technical progress results in on-going changes. We must reserve the right to include these changes in the product.

The illustrations are not binding for production.

## Model T6

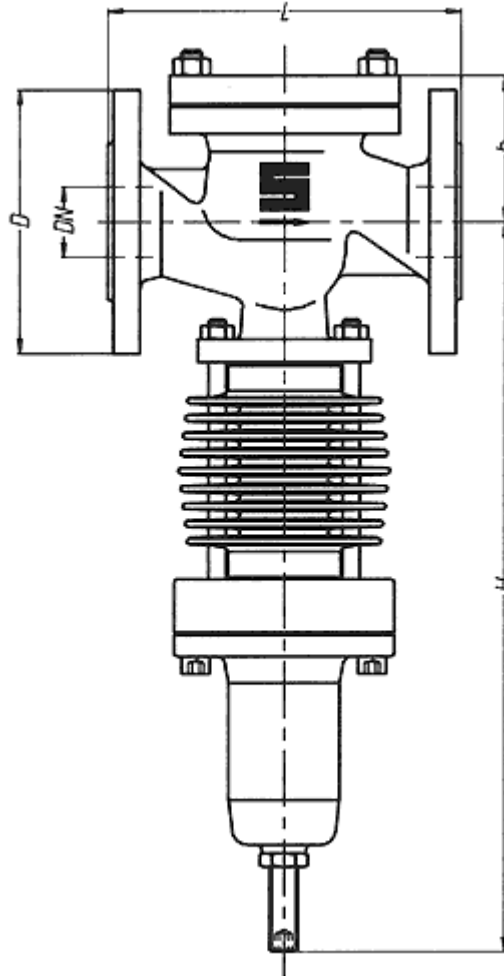

DN	Flanges PN16 GG20				Flanges PN25/40 GS-C25				L	H	h
	D	k	z	i	D	k	z	i			
15	95	65	4	14	95	65	4	14	130	435	90
20	105	75	4	14	105	75	4	14	150	435	90
25	115	85	4	14	115	85	4	14	160	435	90
32	140	100	4	18	140	100	4	18	180	455	120
40	150	110	4	18	150	110	4	18	200	455	120
50	165	125	4	18	165	125	4	18	230	605	130
65	185	145	4	18	185	145	8	18	290	635	155
80	200	160	8	18	200	160	8	18	310	800	180
100	220	180	8	18	235	190	8	23	350	825	180

Dimensions in mm

Installation lengths to DIN 3202 Part 1 - Tab. 4.1 / F1

DN	15	20	25	32	40	50	65	80	100
GG	11.4	11.4	12.5	14.5	16.0	35.0	39.5	52.5	68.0
GS	12.0	12.0	13.0	16.0	18.0	37.5	43.0	58.0	77.0

Weights ~ kg/piece

### Critical flow for saturated steam, Model T 6

#### Quantity of steam per DN in kg/h at $\alpha = 0.2$ ; Upstream pressure side

	p [bar <sub>abs</sub> ]	DN											
		15	20	25	32	40	50	65	80	100	125	150	200
53.2 m <sup>3</sup> /s	1.1	21	38	59	94	154	238	405	607	952	1545	2140	3810
	1.2	23	41	64	101	167	257	437	655	1028	1670	2313	4112
	1.3	25	44	70	110	181	279	474	711	1116	1813	2511	4464
	1.4	27	48	75	119	195	300	510	765	1200	1951	2702	4803
	1.5	29	51	80	127	208	320	545	818	1283	2085	2887	5133
	1.6	30	54	85	135	222	342	581	871	1366	2220	3074	5466
	1.7	32	58	91	143	236	363	617	926	1452	2360	3267	5808
	1.8	34	61	95	151	248	382	649	973	1526	2480	3434	6105
	1.9	36	64	101	159	262	402	684	1026	1610	2616	3622	6438
	2.0	38	68	106	167	275	424	720	1081	1695	2755	3814	6781
	2.2	42	74	116	184	302	465	790	1185	1859	3021	4183	7437
	2.4	45	81	126	200	329	506	860	1289	2022	3286	4550	8090
	2.6	49	87	136	215	354	545	926	1389	2179	3541	4903	8717
	2.8	52	92	144	227	373	575	977	1465	2298	3735	5171	9194
	3.0	56	101	157	248	409	629	1069	1603	2514	4086	5657	10058
	3.5	65	116	182	287	472	727	1236	1854	2908	4726	6543	11632
	4.0	75	133	207	328	539	830	1411	2116	3319	5394	7468	13277
	4.5	84	149	232	367	604	929	1580	2369	3717	6040	8367	14867
	5.0	93	165	258	408	671	1032	1755	2632	4129	6709	9290	16515
	5.5	99	176	274	433	714	1097	1865	2798	4389	7132	9875	17555
6.0	111	197	308	486	800	1230	2092	3138	4922	7998	11074	19686	
6.5	119	213	332	525	864	1329	2259	3388	5315	8637	11959	21261	
7.0	129	229	358	565	930	1431	2433	3649	5724	9302	12879	22896	
7.5	138	245	382	604	994	1529	2599	3899	6116	9939	13761	24464	
8.0	146	260	407	643	1058	1628	2767	4150	6510	10579	14648	26042	
8.5	155	277	432	683	1124	1729	2940	4409	6917	11240	15563	27667	
9.0	164	292	456	720	1185	1823	3098	4648	7290	11847	16403	29162	
9.5	173	307	480	759	1249	1921	3266	4899	7684	12487	17289	30736	
10.0	182	323	505	798	1312	2019	3433	5149	8077	13125	18173	32307	
10.5	191	339	530	837	1378	2120	3604	5406	8480	13780	19080	33920	
11.0	200	355	555	877	1443	2220	3774	5661	8880	14430	19980	35520	
12.0	218	387	605	956	1573	2420	4115	6172	9682	15733	21784	38726	
13.0	235	417	652	1030	1695	2608	4434	6651	10433	16953	23474	41731	
14.0	252	449	701	1108	1822	2804	4766	7150	11215	18225	25234	44861	
15.0	270	481	751	1187	1954	3006	5110	7665	12023	19538	27052	48093	
16.0	288	513	801	1266	2083	3204	5447	8170	12816	20826	28836	51264	
17.0	306	545	850	1343	2210	3400	5780	8671	13601	22101	30602	54403	
18.0	324	575	899	1420	2336	3595	6111	9166	14378	23365	32351	57514	
19.0	342	607	949	1499	2466	3795	6451	9676	15178	24665	34151	60714	
20.0	357	635	993	1568	2581	3971	6750	10126	15883	25810	35737	63533	
21.0	376	669	1046	1653	2719	4184	7112	10669	16735	27195	37654	66941	
23.0	413	735	1148	1814	3985	4592	7807	11710	18369	29849	41330	73475	
25.0	449	798	1247	1969	3241	4986	8476	12714	19944	32409	44874	79776	
27.0	484	861	1346	2126	3498	5382	9149	13724	21528	34983	48438	86112	
29.0	520	924	1444	2282	3755	5777	9820	14730	23106	37548	51989	92426	
30.0	538	957	1496	2363	3889	5983	10170	15256	23930	38887	53843	95722	
33.0	590	1050	1640	2592	4265	6561	11153	16730	26243	42645	59047	104973	
	Kv	1.8	3.2	5.0	7.9	13.0	20.0	34.0	51.0	80.0	130.0	180.0	320.0

$$G = Kv \times \psi_{\max} \times \sqrt{j} \times \sqrt{p}$$

$$(Q = Kv \times \psi_{\max} \times \sqrt{v} \times \sqrt{p})$$

$$G = t/h$$

$$j = t/m^3$$

$$Kv = m^3/h$$

$$p = \text{bar}_{\text{abs}}$$

$$Q = m^3/h$$

$$\psi_{\max} = 0.450 \text{ (saturated steam)}$$

$$v = m^3/t$$

<b>Mass flow table for saturated steam, Model T 6</b>												
<b>Quantity of steam per DN in kg/h at 40 m/s ; Downstream pressure side</b>												
p [bar]	DN											
	15	20	25	32	40	50	65	80	100	125	150	200
0.1	16	29	45	73	115	179	303	460	715	1120	1610	2870
0.2	18	31	48	79	124	194	328	498	775	1215	1750	3110
0.3	19	34	52	85	134	209	353	535	835	1310	1880	3350
0.4	20	36	56	92	144	224	380	575	895	1405	2020	3590
0.5	22	39	60	99	154	239	405	615	955	1500	2170	3820
0.6	23	41	64	105	163	254	430	650	1015	1590	2290	4060
0.7	24	43	68	110	173	269	455	690	1075	1680	2420	4300
0.8	26	46	72	116	182	284	480	725	1135	1770	2550	4540
0.9	27	48	75	122	191	299	505	765	1195	1660	2680	4780
1.0	28	50	78	128	200	314	530	800	1250	1950	2820	5020
1.2	31	55	86	140	219	343	580	880	1360	2140	3080	5500
1.4	34	60	93	152	238	372	625	950	1480	2320	3350	5950
1.6	36	65	100	164	257	401	675	1025	1600	2500	3600	6420
1.8	39	69	107	176	275	430	725	1100	1720	2680	3850	6890
2.0	42	74	115	188	294	460	775	1180	1840	2870	4125	7360
2.5	48	84	132	217	338	530	890	1355	2120	3300	4750	8450
3.0	54	96	150	246	385	600	1010	1540	2400	3750	5400	9650
3.5	60	108	168	275	430	670	1130	1720	2680	4200	6050	10700
4.0	67	119	185	305	475	740	1250	1900	2960	4650	6650	11800
4.5	73	130	202	335	520	810	1370	2080	3240	5075	7300	13050
5.0	79	141	220	365	565	880	1490	2250	3520	5500	7900	14100
5.5	85	152	237	395	605	950	1600	2430	3800	5925	8500	15150
6.0	92	163	254	420	655	1020	1720	2610	4080	6350	9125	16300
6.5	98	174	271	445	695	1085	1840	2790	4360	6775	9750	17400
7.0	104	185	288	475	740	1160	1960	2970	4640	7200	10375	18500
7.5	110	196	305	500	785	1220	2070	3140	4900	7650	11000	19600
8.0	117	207	323	530	830	1290	2180	3320	5180	8100	11625	20700
8.5	123	218	341	560	875	1365	2300	3500	5450	8550	12250	21800
9.0	129	229	358	585	915	1430	2410	3670	5720	8975	12875	22900
9.5	135	240	375	615	960	1500	2530	3840	6000	9400	13500	24000
10.0	141	252	392	645	1000	1570	2650	4020	6270	9825	14125	25100
11.0	154	273	427	700	1090	1710	2880	4380	6800	10700	15300	27300
12.0	166	294	461	750	1180	1840	3100	4730	7300	11550	16500	29400
13.0	178	316	495	810	1270	1980	3340	5080	7850	12400	17750	31600
14.0	190	338	530	870	1355	2120	3570	5400	8400	13200	19000	33800
15.0	202	360	565	925	1440	2250	3800	5750	8950	14100	20300	36000
16.0	215	382	600	980	1530	2390	4030	6100	9550	15000	21600	38200
17.0	227	404	630	1020	1620	2530	4270	6450	10100	15900	22800	40400
18.0	240	427	665	1090	1710	2670	4500	6800	10650	16750	24000	42600
19.0	252	450	700	1145	1790	2800	4740	7150	11200	17600	25200	44800
20.0	263	473	730	1200	1870	2930	4950	7500	11750	18400	26500	47000
22.0	288	510	800	1310	2050	3200	5400	8200	12800	20000	28800	51000
24.0	312	555	870	1420	2220	3470	5850	8900	13900	21700	31200	55200
26.0	337	600	940	1530	2400	3750	6300	9600	15000	23400	33700	60400
28.0	362	645	1010	1650	2580	4020	6800	10300	16100	25100	36200	64600
30.0	387	690	1080	1770	2750	4300	7250	11000	17200	26900	38700	68800
32.0	413	735	1150	1890	2950	4600	7750	11800	18300	28800	41300	73500