

# RCEL

## Electric Actuators 006–009

### INSTALLATION

1. Mounting on valve, see instruction A.
2. Electric wiring, see instruction B.
3. Adjustment, see instruction C.
4. Manual operation, see instruction D.

#### NOTE:

Only electric wiring, acc. to instruction B, is required when the actuator is delivered from Remote Control mounted on a valve. It is adjusted and ready for operation.

### WARNING



**Remove power before the cover is dismantled!**  
**The actuator must be handled with the utmost care when the cover is removed and the power connected!**

### A. MOUNTING ON VALVE

1. Operate the valve manually to fully open or fully closed position before the actuator is mounted.
2. Operate the actuator manually (see instruction D) to fully open or fully closed position.
3. Check that the actuator and valve stem are in correct position. Please note, valve and actuator must be in the same mode (fully open / fully closed) prior to the assembly.
4. Mount the actuator on the valve and check that the actuator and valve stems are centered and aligned. If a mounting bracket is used, the fit must be checked so that no distortion or play exists.
5. Operate the valve manually with the aid of the actuator handwheel and check that the valve moves with normal resistance.
6. Check that all screws are correctly tightened.

### B. ELECTRIC WIRING

**NOTE:** Electric wiring must be carried out by qualified personnel only!

1. Loosen the screws on the cover and lift it off.
2. Check the voltage marked on the actuator label.
3. Connect according to the enclosed wiring diagram or, if the actuator is of standard design, according to the wiring diagram below. The wiring diagram is drawn in unaffected position (the valve in intermediate position).
4. Test run the actuator from the intermediate position checking that the actuator turns in the correct direction.
5. Test run the actuator and check that the limit switches work correctly.
6. Check that the cable entries and possible blind plug are sealed.
7. Mount the cover.

#### Wiring diagram No NU 12000C. Standard.

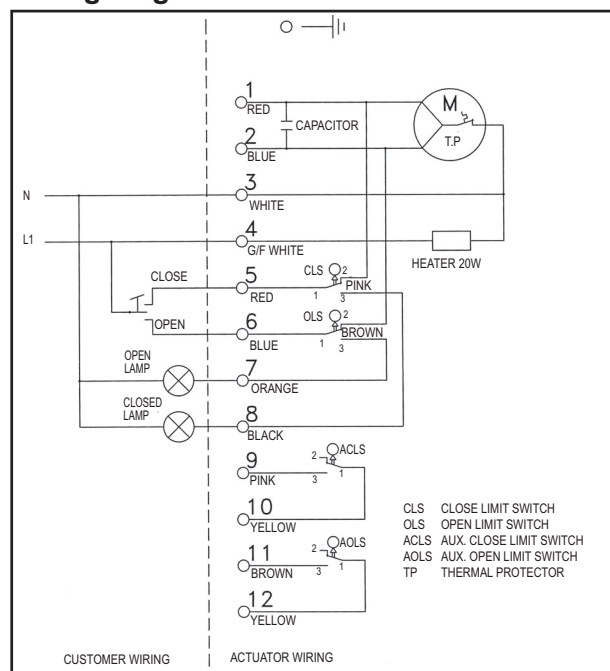

## C. ADJUSTMENT

1. Make the final cam adjustments for the limit switches (if necessary) acc. to instruction (a) below.
2. Make the final adjustments of the mechanical limit stops (if necessary) acc. to instruction (b) below.
3. Run the actuator from one end position to the other a number of times.
4. Adjust the indicator disc for visual indication so that it relates to the valve position.
5. Test run the actuator and check that the limit indicators are working correctly.
6. Mount the cover.

### (a) Adjustment of cams for limit switches:

1. Operate the actuator manually to closed position.
2. Adjust the cam for closed position (lower cam marked CLS).
3. Operate the actuator manually to open position.
4. Adjust the cam for open position (upper cam marked OLS).
5. Test run the actuator.

### (b) Adjustment of mechanical limit stops for soft-seated valves:

1. Operate the actuator electrically to closed position.
2. Adjust the right set screw for closed position so that it makes contact, back one turn and tighten the lock nut.
3. Operate the actuator electrically to open position.
4. Adjust the left set screw for open position so that it makes contact, back one turn and tighten the lock nut.

(For adjustment of metal-seated butterfly valves, please contact our technicians.)

## D. MANUAL OPERATION

1. Pull the engagement lever towards the handwheel until it remains in position.
2. Turn the handwheel until the valve reaches the required position.
3. Turn clockwise to close and anti-clockwise to open.

### NOTE!

The engagement lever returns automatically to auto-position when the actuator is operated electrically.

