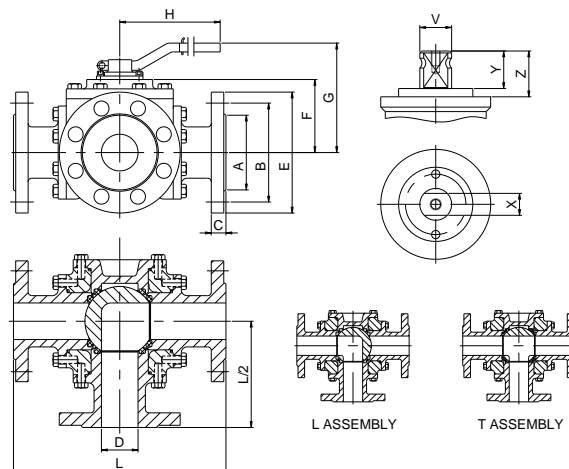
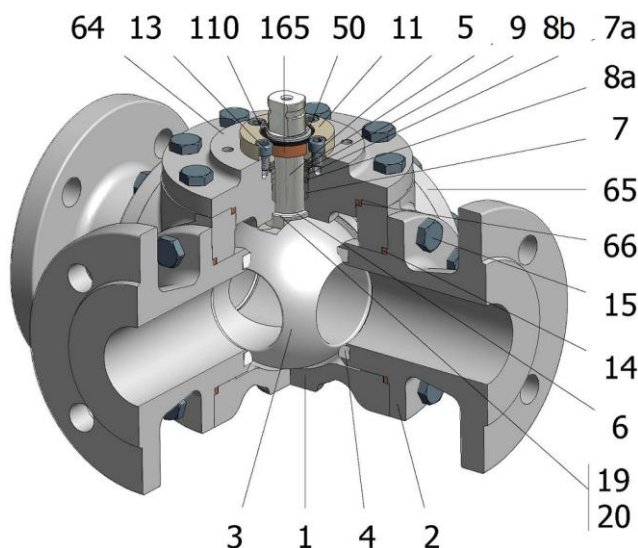

FIG.Z 86 TTT PN16 DN25-200 L/T



Position	Description	Material
01	Body 1	S.S. 1.4408
02	Body 2	S.S. 1.4408
03	Ball	S.S. 1.4408
04	Seat	PTFE (modified)
05	Stem	S.S. 1.4401
06	Stem seal	PTFE (modified)+FG
07	Stem packing	PTFE (modified)
07a	Stem packing 2	Graphite
08a	Gland packing 1	S.S. 1.4401
08b	Gland packing 2	S.S. 1.4401
09	Spring washer	S.S. 1.4310
11	Cover	S.S. 1.4408
13	Cover bolt	A4-70
14	Body seal 1	PTFE (modified)
15	Body bolt	A4-70
16	Handle	WCB
17	Handle bolt	1.045(8.8)
19	Spring	S.S. 1.4401
20	Antistatic ball	S.S. 1.4401
50	Subjection ring	S.S. 1.4301
64	Body cover	S.S. 1.4408
65	Body blind	S.S. 1.4408
66	Body cover seal	PTFE (modified)
110	Subjection ring seal	S.S. 1.4401 Nitrided
165	Stem bearing	PTFE (modified)+FG

General features

- Floating ball.
- Split body.
- Full bore.
- Soft seat.
- Three way
- Anti Blow out proof stem.
- Autoadjustable packing.
- Anti static device.
- Self-cavity pressure relief.

Standards

- Top flange ISO 5211
- Flanges EN 1092-01
- Testing EN-12266, ISO 5208
- Design EN-12516, ISO 17292

Official approvals

- TA-LUFT VDI 2440
- ISO 15848-1
- ATEX 2014/34/EU
- PED 2014/68/EU
- SIL 3 CAPABLE

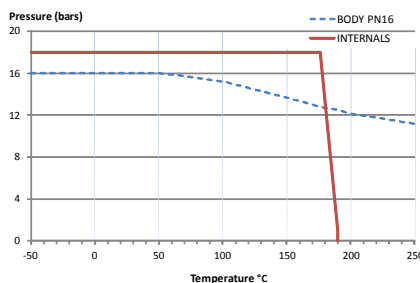

PEKOS GROUP CERTIFICATES:

ISO 9001: 2015 / 2014/68/EU /API-6D



DIMENSIONS & Technical information

DN	PN	D	L	E	A	B	C	F	H	G	V	X	Y	Z	n x d	ISO 5211	Torque	MAST	Weight
25	16	25	230	115	68	85	18	67	185	117	18	14	17	19,5	4 x 14	F05	21	95	14
40	16	40	260	150	88	110	18	82	293	136	22	17	20	30	4 x 18	F07	47	250	22
50	16	50	290	165	102	125	20	90	293	144	22	17	20	30	4 x 18	F07	69	250	30
65	16	65	340	185	122	145	18	109	450	182	28	22	22	40	8 x 18	F10	83	523	47
80	16	80	380	200	138	160	20	132	740	205	36	27	35	50	8 x 18	F12	128	1073	65
100	16	100	430	220	158	180	20	147	740	220	36	27	35	50	8 x 18	F12	165	1073	95
150	16	150	480	285	212	240	22	216	-	-	48	36	40	63	8 x 22	F14	570	2544	180
200	16	200	600	340	268	295	24	258	-	-	48	36	40	63	12 x 22	F14	810	2544	300

\*\* Depending on service conditions.

\* Dimensions are in mm.

\* Torque & MAST are in Nm.

\* Weight is in Kilograms

\* Torque values have been measured ΔP at maximum rating at room temperature