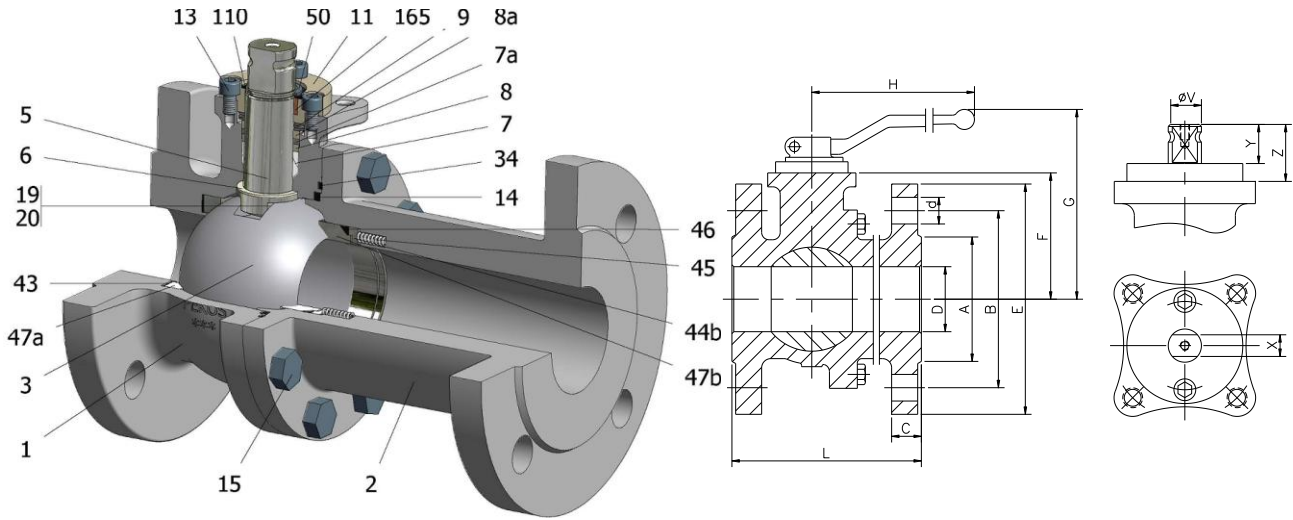

FIG.ZMS 26 CGGG PN40 DN15-125 F1



Position	Description	Material
01	Body 1	S.S. 1.4408
02	Body 2	S.S. 1.4408
03	Ball	1.4408+Cr-Carbide
05	Stem	XM-19
06	Stem seal	S.S. 1.4401 Nitrided
07	Stem packing	Graphite
07a	Stem packing 2	Graphite
08a	Gland packing 1	S.S. 1.4401
08b	Gland packing 2	S.S. 1.4401
09	Spring washer	Inconel X718
11	Cover	S.S. 1.4408
13	Cover bolt	A4-70
14	Body seal 1	Graphite
15	Body bolt	A4-70
16	Handle	WCB
17	Handle bolt	1.045(8.8)
19	Spring	S.S. 1.4401
20	Antistatic ball	S.S. 1.4401
34	Body seal 2	Graphite
43	Seat seal	Graphite
44b	Ring seat 2	S.S. 1.4401
45	Spring seat	Inconel X750
46	Seat seal	Graphite
47	Metal seat	1.4401+Cr-Carbide
50	Subjection ring	S.S. 1.4021
110	Subjection ring seal	S.S. 1.4401 Nitrided
165	Stem bearing	Carbongraphite

**General features**

- Floating ball.
- Split body.
- Full bore.
- Metal to Metal.
- Bidirectional.
- Spring loaded seat system.
- Anti Blow out proof stem.
- Autoadjustable packing.
- Anti static device.
- Self-cavity pressure relief.

**Standards**

- Top flange ISO 5211
- Flanges EN 1092-01
- Face to face EN 558
- Testing EN-12266, ISO 5208
- Design EN-12516, ISO 17292

**Official approvals**

- CERTIFICATE FIRE SAFE
- TA-LUFT VDI 2440
- ISO 15848-1
- ATEX 2014/34/EU
- PED 2014/68/EU
- SIL 3 CAPABLE

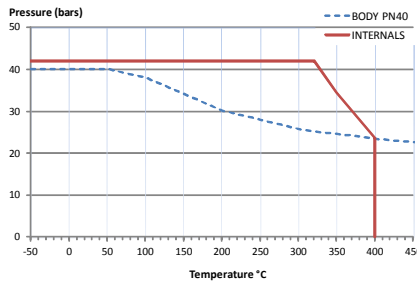

**PEKOS GROUP CERTIFICATES:**

ISO 9001-2008 / 2014/68/EU /API-6D



**DIMENSIONS & Technical information**

DN	PN	D	L	E	A	B	C	F	H	G	V	X	Y	Z	n x d	ISO 5211	Torque	MAST	Weight
15	40	15	130	95	45	65	16	51	185	105	14	11	11	13,5	4 x 14	F05	25	81	3
20	40	20	150	105	58	75	18	53	185	107	14	11	11	13,5	4 x 14	F05	34	81	4
25	40	25	160	115	68	85	18	59	185	113	18	14	17	19,5	4 x 14	F05	46	175	5
32	40	32	180	140	78	100	18	64	185	118	18	14	17	19,5	4 x 18	F05	68	175	7
40	40	40	200	150	88	110	18	75	293	145	22	17	20	30	4 x 18	F07	90	464	9
50	40	50	230	165	102	125	20	83	293	153	22	17	20	30	4 x 18	F07	137	464	13
65	40	65	290	185	122	145	22	96	293	166	22	17	20	30	8 x 18	F07	222	464	20
80	40	80	310	200	138	160	24	114	450	205	28	22	22	40	8 x 18	F10	320	969	26
100	40	100	350	235	162	190	24	128	450	220	28	22	22	40	8 x 22	F10	445	969	36
125	40	125	400	270	188	220	26	157	-	-	36	27	35	50	8 x 26	F12	845	1990	48

\*\* Depending on service conditions.

\* Dimensions are in mm.

\* Torque & MAST are in Nm.

\* Weight is in Kilograms

\* Torque values have been measured ΔP at maximum rating at room temperature