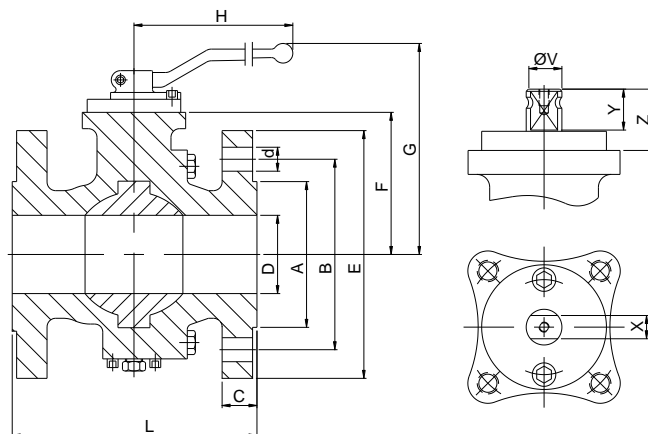
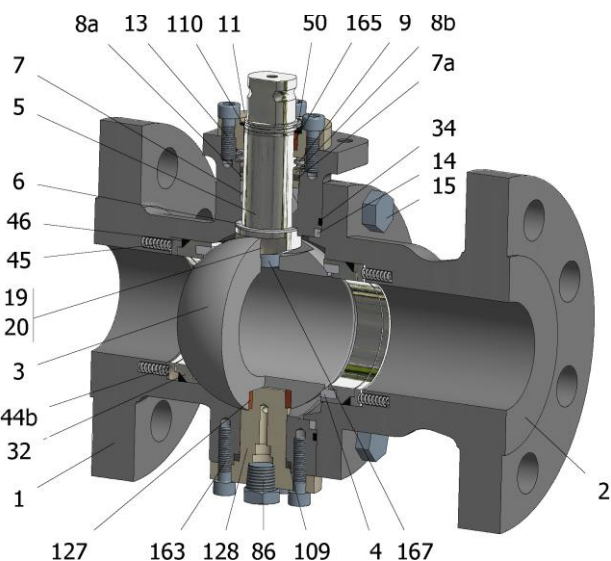

FIG.ZGS 24 SSSG PN40 DN40-100 F1



Position	Description	Material
01	Body 1	C.S. 1.0352
02	Body 2	C.S. 1.0352
03	Ball	S.S. 1.4408
04	Seat	PTFE (modified)+CG
05	Stem	D.S.S. 1.4462
06	Stem seal	PTFE (modified)+CG
07	Stem packing	PTFE (modified)+CG
07a	Stem packing 2	Graphite
08a	Gland packing 1	S.S. 1.4401
08b	Gland packing 2	S.S. 1.4401
09	Spring washer	S.S. 1.4310
11	Cover	S.S. 1.4408
13	Cover bolt	A4-70
14	Body seal 1	PTFE (modified)+CG
15	Body bolt	A2-70
16	Handle	WCB
17	Handle bolt	1.045(8.8)
19	Spring	Inconel X750
20	Antistatic ball	Inconel 625
34	Body seal 2	Graphite
44a	Ring seat 1	S.S. 1.4401
44b	Ring seat 2	S.S. 1.4401
45	Spring seat	Inconel X750
46	Seat seal	Graphite
50	Subjection ring	S.S. 1.4021
86	Drain plug	C.S. A350 LF2
86a	Vent plug	C.S. A350 LF2
109	Cover seal	Graphite
110	Subjection ring seal	S.S. 1.4401 Nitrided
127	Stem bearing	MU
128	Body cover 2	C.S. 1.0352
163	Body cover 2 bolt	A4-70
165	Stem bearing	PTFE (modified)+FG
167	Stem guide bolt	A2-70 Nitrided

General features

- Full trunnion.
- Split body.
- Full bore.
- Soft seat.
- Bidirectional.
- Spring loaded seat system.
- Anti Blow out proof stem.
- Autoadjustable packing.
- Anti static device.
- Self-cavity pressure relief.
- Double Block and Bleed.

Standards

- Top flange ISO 5211
- Flanges EN 1092-01
- Face to face EN 558
- Design EN-12516, ISO 17292
- Testing EN-12266, ISO 5208

Official approvals

- CERTIFICATE FIRE SAFE
- TA-LUFT VDI 2440
- ISO 15848-1
- ATEX 2014/34/EU
- PED 2014/68/EU
- SIL 3 CAPABLE

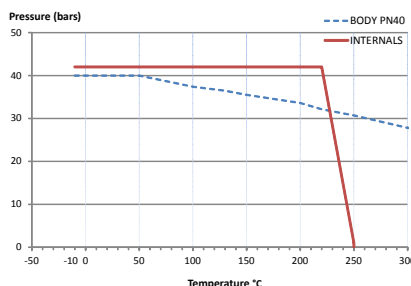

PEKOS GROUP CERTIFICATES:

ISO 9001-2008 / 2014/68/EU / API-6D

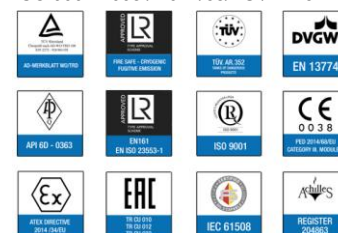

DIMENSIONS & Technical information

DN	PN	D	L	E	A	B	C	F	H	G	V	X	Y	Z	n x d	ISO 5211	Torque	MAST	Weight
40	40	40	200	150	88	110	18	75	293	144	22	17	20	30	4 x 18	F07	60	550	12
50	40	50	230	165	102	125	20	84	293	153	22	17	20	30	4 x 18	F07	80	550	17
80	40	80	310	200	138	160	24	107	450	198	28	22	22	40	8 x 18	F10	190	1147	38
100	40	100	350	235	162	190	24	113	450	204	28	22	22	40	8 x 22	F10	250	1147	60

\*\* Depending on service conditions.

\* Dimensions are in mm.

\* Torque & MAST are in Nm.

\* Weight is in Kilograms

\* Torque values have been measured ΔP at maximum rating at room temperature