

# **DREHMO**

## VALVE ACTUATORS

A member of the AUMA Group

## **DREHMO i-matic Ex (x-matic)**

**Electric actuators with integral  
controls for ATEX and IECEx**



Assembly, operation and servicing instructions  
for multi-turn, part-turn and linear actuators

Part. no: 383905

Revision: 2.5

Date: November 08, 2019

This operating manual is part of the supply and should be kept for future use.  
Regard the additional description of the integrated control unit according to  
the electric type of the actuator IM (383347) or IMC (383352)!

---

# Table of Contents

<b>1</b>	<b>Safety instructions</b>	<b>4</b>
1.1	Basic information on safety . . . . .	4
1.2	Range of application . . . . .	5
1.3	Warnings . . . . .	6
<b>2</b>	<b>Identification</b>	<b>8</b>
2.1	Name plates . . . . .	8
2.2	Actuator designation . . . . .	9
<b>3</b>	<b>Transport, storage and packaging</b>	<b>10</b>
3.1	Transport . . . . .	10
3.2	Storage . . . . .	11
3.3	Packaging . . . . .	11
<b>4</b>	<b>Mounting to valve</b>	<b>12</b>
4.1	Handwheel operation . . . . .	12
4.2	Removal and fitting of stem nut (output drive type A) . . . . .	13
4.3	Removal and fitting of stem nut (output drive type A-HP) . . . . .	13
4.4	Insulating flange . . . . .	15
4.5	Rain protection hood . . . . .	16
4.6	Assembly . . . . .	16
4.7	Additional settings for part-turn actuators . . . . .	19
<b>5</b>	<b>Electrical connection</b>	<b>24</b>
5.1	Important notes . . . . .	24
5.2	Connection terminals . . . . .	26
5.3	Opening the pluggable electrical connection . . . . .	27
<b>6</b>	<b>Local controls</b>	<b>28</b>
6.1	Local indication lights . . . . .	29
6.2	Operation . . . . .	29
6.3	Access protection of local controls . . . . .	31
6.4	Language selection . . . . .	31
6.5	Display elements . . . . .	32
6.6	Contrast setting . . . . .	35
6.7	Parameterisation and diagnostics interfaces . . . . .	36
<b>7</b>	<b>Commissioning</b>	<b>39</b>
7.1	Connection of the power supply . . . . .	39
7.2	Valve-specific basic settings . . . . .	41
7.3	Parameter setting . . . . .	45
7.4	Fault indications . . . . .	45
<b>8</b>	<b>Servicing and maintenance</b>	<b>46</b>
8.1	Maintenance . . . . .	46

---

8.2	Troubleshooting and corrective actions . . . . .	47
8.3	Oil filling . . . . .	47
8.4	Cleaning . . . . .	48
8.5	Disposal . . . . .	49
<b>9</b>	<b>Technical data</b>	<b>50</b>
9.1	Contact and water protection . . . . .	50
9.2	Overview Technical data . . . . .	51
9.3	Permissible terminal compartment . . . . .	54
9.4	Types of duty for different versions . . . . .	56
<b>10</b>	<b>External warnings</b>	<b>58</b>
<b>11</b>	<b>Certificates</b>	<b>59</b>

---

# 1 Safety instructions

This section deals with basic, safety-relevant information relating to DREHMO actuators. We would like to ask you to thoroughly read the instructions prior to working on the actuators.

## 1.1 Basic information on safety

### **Standards/directives**

DREHMO products are designed and manufactured in compliance with recognised standards and directives. This is certified in a Declaration of Incorporation and an EC Declaration of Conformity. Plant operators or plant manufacturers must ensure that all legal requirements, directives, guidelines, national regulations and recommendations with respect to assembly, electrical connection, commissioning and operation are met at the place of installation.

### **Safety instructions/warnings**

All personnel working with this device must be familiar with the safety and warning instructions in this manual and observe the instructions given. Safety instructions and warning signs on the device must be observed to avoid personal injury or property damage.

### **Qualification of staff**

Assembly, electrical connection, commissioning, operation, and maintenance must be carried out by suitably qualified personnel authorised by the plant operators or plant manufacturers only. Prior to working on this product, the staff must have thoroughly read and understood these instructions as well as the the additional instructions for the integral control and, furthermore, know and observe officially recognised rules regarding occupational health and safety. Work performed in potentially explosive atmospheres is subject to special regulations which have to be observed. The plant operators or plant manufacturers are responsible for respect and control of these regulations, standards, and laws.

### **Commissioning**

Prior to commissioning, it is important to check that all settings meet the requirements of the application. Incorrect settings might present a danger to the application, e.g. cause damage to the valve or the installation. The manufacturer will not be held liable for any consequential damage. Such risk lies entirely with the user.

## 1. SAFETY INSTRUCTIONS

---

### Operation

Prerequisites for safe and smooth operation:

- Correct transport, proper storage, mounting and installation, as well as careful commissioning.
- Only operate the device if it is in perfect condition while observing these instructions.
- Immediately report any faults and damage and allow for corrective measures.
- Observe recognised rules for occupational health and safety.
- Observe national regulations.
- During operation, the housing warms up and surface temperatures  $>60^{\circ}\text{C}$  may occur. To prevent possible burns, we recommend checking the surface temperature using an appropriate thermometer and wearing protective gloves, if required, prior to working on the device.

### Protective measures

The plant operators or plant manufacturers are responsible for implementing required protective measures on site, such as enclosures, barriers, or personal protective equipment for the staff.

### Maintenance

To ensure safe device operation, the maintenance instructions included in this manual must be observed.

Any device modification requires prior consent of the manufacturer.

## 1.2 Range of application

DREHMO actuators are designed for the operation of gate valves, butterfly valves, and ball valves. The devices described below are approved for use in the potentially explosive atmospheres of zones 1 and 2. The described devices may also be used in potentially explosive atmospheres of zones 21 and 22 in case of appropriate ATEX approval. If temperatures outside the range for ambient temperature specifications as marked on the name plate (e.g. due to hot media) are to be expected, you are requested to contact the manufacturer. Other applications require explicit (written) confirmation by the manufacturer. The following applications are not permitted, e.g.:

- Industrial trucks according to EN ISO 3691
- Lifting appliances according to EN 14502
- Passenger lifts according to DIN 15306 and 15309
- Service lifts according to EN 81-1/A1
- Escalators
- Continuous duty
- Buried service
- Continuous submersion (observe enclosure protection)
- Potentially explosive areas of zones 0 and 20
- Potentially explosive areas of group I (mining)
- Radiation exposed areas in nuclear power plants

No liability can be assumed for inappropriate or unintended use. Observance of these operation instructions is considered as part of the device's designated use.

**Information:** These instructions apply to the clockwise closing standard version, i.e. the driven shaft turns clockwise to close the valve.

## 1.3 Warnings

The following warnings draw special attention to safety-relevant sections in these operation instructions, each marked by the appropriate signal word (**DANGER**, **WARNING**, **CAUTION**, **NOTICE**).

<b>DANGER</b>	Indicates an imminently hazardous situation with a high level of risk. Failure to observe this warning could result in death or serious injury.
<b>WARNING</b>	Indicates a potentially hazardous situation with a medium level of risk. Failure to observe this warning could result in death or serious injury.
<b>CAUTION</b>	Indicates a potentially hazardous situation with a low level of risk. Failure to observe this warning may result in minor or moderate injury. May also be used with property damage.
<b>NOTICE</b>	Potentially hazardous situation. Failure to observe this warning may result in property damage. Not used for injuries or death.

Structure of the warning instructions for **DANGER**, **WARNING**, **CAUTION** and **NOTICE**:



### **WARNING**

#### **Type of hazard and respective source!**

Possible cause(s) in case of failure to respect safety instructions, actions for risk avoidance and further optional measures.

The safety symbol of the triangle on the base line is used for warning of an potential risk of injury. The signal word indicates the level of hazard. Failure to observe the blue information symbol may result in property damage (not used for injuries or death).



### **NOTICE**

#### **Type of hazard and respective source!**

Possible cause(s) in case of failure to respect safety instructions, actions for risk avoidance and further optional measures.

## 2 Identification

The following section describes the characteristics allowing identification of the respective DREHMO actuator.

### 2.1 Name plates

Each actuator is equipped with an actuator and a motor name plate including information required for unambiguous identification (refer to figure 2.1). For commissioning, service and maintenance, additional actuator-relevant data is indicated on the name plates.

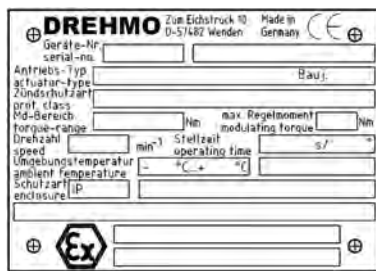

Figure 2.1: Actuator name plate for explosion-proof version

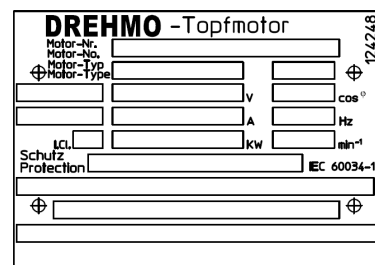

Figure 2.2: Motor name plate

Please always state the serial number for any product inquiries. The product can be unambiguously identified using this number and the technical data as well as order-related data pertaining to the device can be requested.



## 2.2 Actuator designation

The following example is used to explain the actuator designation:

Value range	D	*	*	*	*	-	*	-	*		*
Position	1	2	3	4	5	6	7	8	9	10	11

Position	Value range	Signification
1	D	DREHMO actuator
2		Multi-turn actuator
	P	Part-turn actuator
3		Actuator without controls
	MC	Actuator with C-matic controls
	iM	Actuator with i-matic or i-maticC controls
4		Actuator for open-close operation, type of duty S2 <15 Min
	R	Type of duty for modulating actuator: S4 max. 35 %ED
5	30 to 2000	Nominal torque in Nm for multi-turn actuators D...
	30 to 1800	Nominal torque in Nm for part-utrn actuators DP...
6	-	Line
7	A, AF, B, B1, B2, B3, B3DO, B4, C, D, DO, DOU, DSTO, DSTU, E, EDO	Valve attachment types for multi-turn actuators according to EN ISO 5210
	B, V, W, L/D, H, FH, FW	Valve attachment types for part-turn actuators according to EN ISO 5211
8	-	Line
9	5 to 160 (50 Hz)	Output drive speed in rpm for multi-turn actuators D...
	6 to 192 (60 Hz)	
	8 to 60 (50 Hz)	Operating time for 90° in seconds for part-turn actuators DP...
	6 to 50 (60 Hz)	
10		Blank
11		Standard actuator
	Ex	Explosion-proof actuator

Table 2.2: Type code

## 3 Transport, storage and packaging

This section of the operation instructions deals with safe transport, appropriate storage and packaging. The information given shall avoid property damage and personal injury.

### 3.1 Transport

**DANGER**  
**Hovering load! Risk of death or serious injury**



- Do NOT stand below hovering load.
- Fix ropes or slings around housing, NOT to handwheel, stem protection cover or motor eyebolt.
- If the actuator is mounted to a valve, fix ropes or slings at the valve.
- If a gearbox is mounted to the actuator, fix ropes or slings at gearbox.

Please refer to figure 3.1 below for appropriate actuator transport.



Figure 3.1: Transport

## 3.2 Storage

Mounting or storage in humid environments requires appropriate actions for avoiding condensation inside the actuator. If the actuator is equipped with an externally supplied additional heater, this heater must be predominantly used. Otherwise, switch on the operating voltage. If the device is to be stored for a long period (more than 6 months), the following points must be observed:

- Protect uncoated surfaces, in particular the output drive parts and mounting surface with corrosion protection agent prior to storage.
- Check uncoated surfaces for corrosion approximately every 6 months.
- Ensure that actuators are fully operational by performing a test run every 6 months.

#### NOTICE

**Danger of corrosion and damage to the control unit due to inappropriate storage**



- Store in a well-ventilated, dry and closed room.
- Protect against dampness from the floor and ambient humidity.
- Cover to protect against dust and dirt.
- Apply suitable corrosion protection agent to uncoated surfaces.
- Switch on device heater.

#### NOTICE

**Damage on display caused by temperatures outside permissible level**



- Make sure that display temperature does not fall below  $-30\text{ }^{\circ}\text{C}$

## 3.3 Packaging

Our products are protected by special packaging for transport when leaving the factory. The packaging consists of environmentally friendly materials which can easily be separated and recycled. We use the following packaging materials: wood, cardboard, paper, and PE foil. For the disposal of the packaging material, we recommend recycling and collection centres.

## 4 Mounting to valve

This section deals with mounting the actuator on a valve, while detailing the specialities of the different version. In any case, check the actuator first for any damage. Replace damaged parts by original spare parts.

DREHMO actuators can be mounted in any position. Mounting is easiest if the vertically fitted valve shaft is freely accessible. To fix the DREHMO actuator to the valve, threaded holes are provided at the actuator mounting flange. The dimensions of the actuator mounting flange with output drive types comply with standards EN ISO 5210 (multi-turn actuators) or EN ISO 5211 (part-turn actuators).

### 4.1 Handwheel operation

Both actuator or valve can be operated manually at any time via the handwheel in case of power failure. Switching between motor operation and handwheel operation is not required. Clockwise rotation of handwheel results in clockwise rotation of output drive (for view on motor name plate).

#### **WARNING**

#### **Damage to actuator and mounted elements by handwheel operation**



- The set tripping torques do not limit the forces applied by the handwheel.
- Manual operation only
- Power drive for handwheel operation is only available on request with the manufacturer.
- Use of levers of any type is not permitted.

## 4.2 Removal and fitting of stem nut (output drive type A)

For output drive type A, make sure that the unbored stem nut (delivered unbored unless stated otherwise) must be provided with a thread bore in compliance with available stem prior to mounting the DREHMO actuator onto the valve.

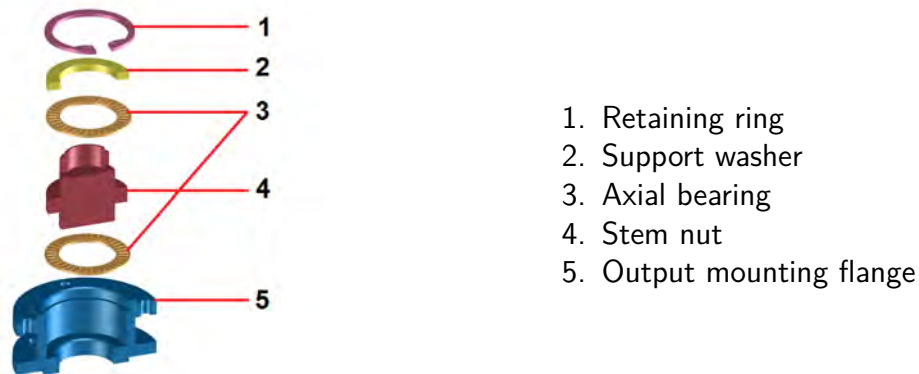

Figure 4.1: Stem nut type A

Remove output mounting flange (5) from actuator. Remove retaining ring (1) and remove stem nut (4) including support washer (2) and axial bearing (3). Perform thread bore. Reverse the process to reassemble stem nut. Apply a thin film of sealing agent (e.g. Curil K2) at sealing faces of output mounting flange (5) prior to assembly.

## 4.3 Removal and fitting of stem nut (output drive type A-HP)

For better distinction, each of the new stem nuts is marked with a turned marking groove at the shoulder circumference.

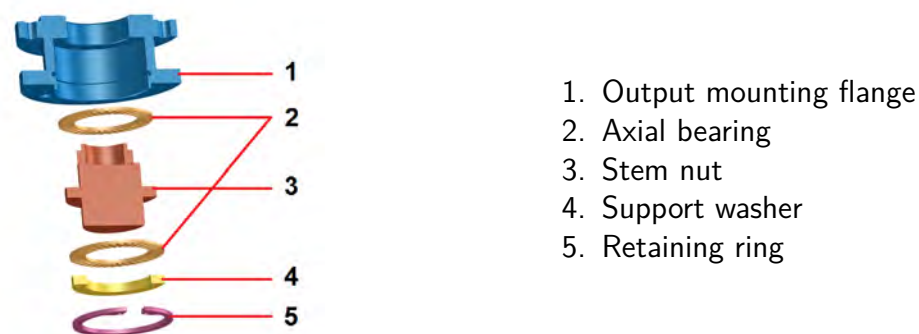

Figure 4.2: Stem nut type A HP with retaining ring

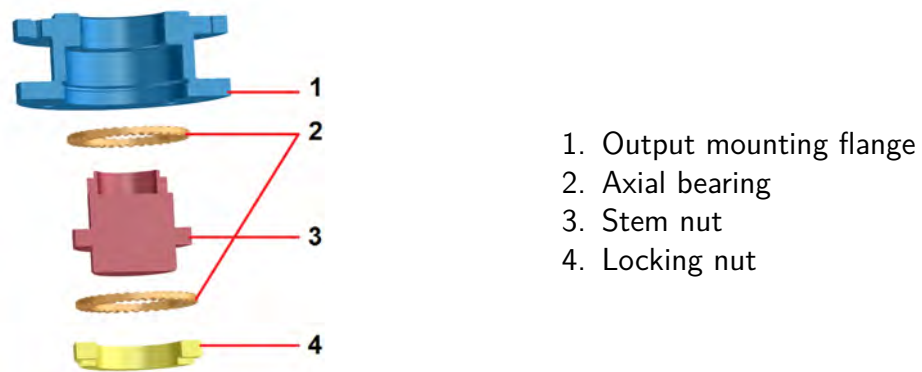

Figure 4.3: Stem nut type A HP with thread ring

Remove retaining ring (5) / locking nut (4) and remove stem nut (3), axial bearing (2). If the output drive has a retaining ring the support washer (4) has to be removed too. Perform thread bore. Reverse the process to reassemble stem nut.

#### **NOTICE**

**Excessive lubricant application can impair the tightness of the actuator**



- The actuators have a lifetime lubrication
- A device for permanent lubrication of a stem (only output drive type A and A-HP) can be inquired of the manufacturer

## 4.4 Insulating flange

When using an insulating flange, heed the length of the screws used. They must not be too long: otherwise the insulating caps within the flange or even the flange as such will be damaged. We therefore recommend using studs according to DIN 938 with a depth of thread of  $1 \times D$  (refer to figure 4.4) for assembly. A remaining width of joint of 0 mm must not be fallen short of.

### NOTICE

**Risk of damage at insulating flanges when using motors with mounted terminal box (standard motors) and horizontal mounting position!**



- Due to the limited permissible forces on the insulating flange, horizontal mounting positions are not allowed for actuators with standard motors (external clamp cage).

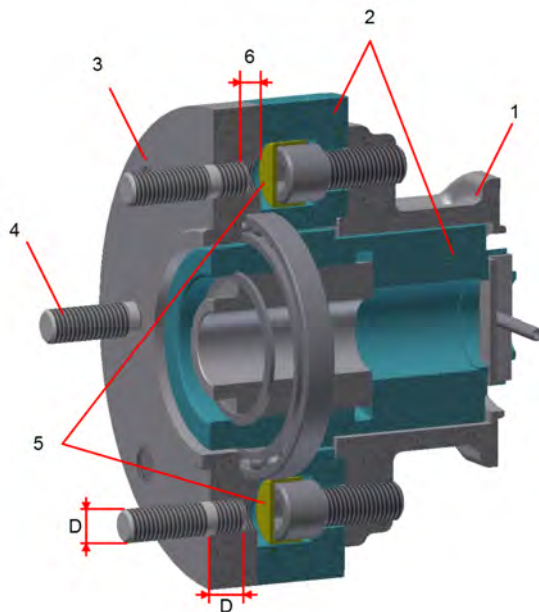

1. Input mounting flange
2. Insulating body
3. Output drive flange
4. Stud
5. Insulating caps
6. Remaining width of joint ( $> 0$  mm)

Figure 4.4: insulating flange

## 4.5 Rain protection hood

For HEW-RUF motors, the rain protection hood (2) is always used in combination with the fan cover (1) (siehe Abbildung 4.5). This is the responsibility of the supplier! The hood must only be disassembled at the customers' for upward mounted shafts (protection hood points downward). For this, the fan cover (1) must be disassembled first. After this, the rain hood (2) with positive connection can be removed. For this, straighten the four lugs (3) using appropriate universal pliers. Finally, the fan cover (1) must be refitted.

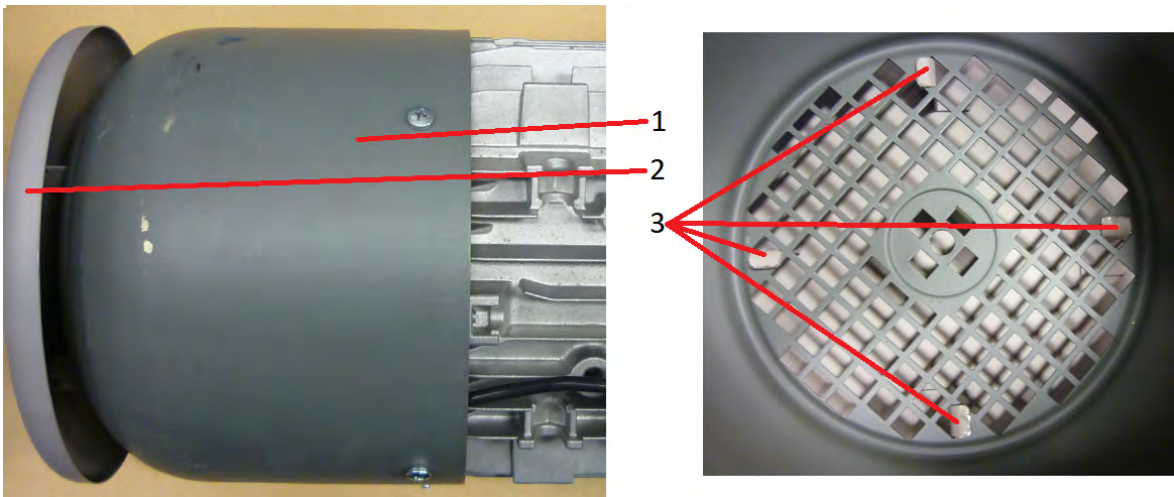

Figure 4.5: Regenschutzhaube

## 4.6 Assembly

### Direct mounting

For direct mounting, the actuator is fitted without intermediate gearing to the valve. For this purpose, part-turn actuators are equipped with an unbored (standard) output drive plug sleeve. The output drive plug sleeve is equipped with splines on the outside (to be coated with appropriate grease prior to assembly) and can therefore be inserted into the actuator at different angles. As standard, multi-turn actuators are available with output drive type B3. Output drives A, B1, B2, B4, E, C and D are available on request.

Align actuator on valve, then rotate the device until fixing holes of actuator and valve align and the output drive is correctly placed on the valve flange. Fasten actuator crosswise to valve using appropriate screws.

Output drive type A is an exception. This output drive type must be fastened to the valve first. Rotate the drive assembly down the valve shaft to mate with the valve flange. Align the fixings and attach loosely, rotate the drive coupling to take up the free play and ensure close coupling of the flanges, before fastening tightly. Then the actuator is placed on the drive assembly and can be rotated to the correct position via the handwheel before fixing tightly into position.



Screw strength class 8.8 ( $\mu_t \approx 0.12$ )										
Threads	M6	M8	M10	M12	M14	M16	M18	M20	M30	M36
Tightening torque in Nm	10	25	49	85	135	210	300	425	1450	2600

Table 4.1: Tightening torques

The actuator is mounted to the valve using an output drive plug sleeve (refer figure 4.6). Ensure compliance of fitting dimensions according to table 4.2 below.

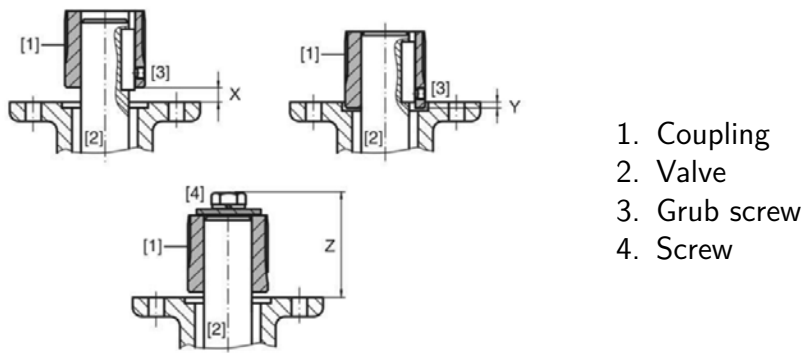

Figure 4.6: Cross sections of different couplings

### NOTICE

**Increased fastening torque for powder coated flanges possibly required**



- Thanks to powder coating on flange surfaces and flange threads, we achieve top quality and permanent corrosion protection. However, increased fastening torque of up to 2 Nm across all screw dimensions might be required. Consequently, tools might already be required when fastening the screws (typically a socket is sufficient). This was considered when specifying the screw connection and is totally uncritical in practice.

1. Use handwheel to run actuator to mechanical end stop.
2. Thoroughly degrease mounting surfaces of output mounting flanges and apply appropriate sealing agent (e.g. Curil K2).
3. Apply a small quantity of grease to the valve shaft [2].
4. Place coupling [1] onto valve shaft [2] and secure against axial slipping by using a grub screw [3], a retaining ring or a screw. Thereby, ensure that dimensions X, Y or Z are observed (refer to figure 4.6 and table 4.2).
5. Apply non-acidic grease at splines of coupling.
6. Fit part-turn actuator.
7. If flange bores do not match thread:
  - a) Slightly rotate handwheel until bores line up.
  - b) If required, shift actuator position by one tooth on the coupling.
8. Fix actuator using suitable screws.

We recommend applying liquid thread sealing material to the screws. Fasten screws cross-wise to a torque according to table 4.1.

Type, size - output mounting flange	X <sub>max</sub> in mm	Y <sub>max</sub> in mm	Z <sub>max</sub> in mm
DP..(R)75/150/299-F05/07	3	2	40
DP..(R)75/150/299-F10	3	2	66
DP..(R)300/450-F10	4	5	50
DP..(R)300/450-F12	4	5	82
DP..(R)600/900-F12	5	10	62
DP..(R)600/900-F14	5	10	102
DP..(R)1200/1800-F14	8	10	77
DP..(R)1200/1800-F16	8	10	127
DP..30,59,119	1		
DP..319,799	1.5		
DP..1599	3		

Table 4.2: Coupling fitting dimensions

### Indirect mounting

For indirect mounting DREHMO actuators can be supplied with base and lever or with base and shaft. Connection between actuator and valve is provided by the customer (e.g. via lever arrangement).

## 4.7 Additional settings for part-turn actuators

### End stops in part-turn actuator

The internal end stops limit the swing angle. They protect the valve in the event of manual handwheel operation. End stop setting is generally performed by the valve manufacturer prior to installing the valve into the pipework.



#### CAUTION

**Exposed, rotating parts (discs/balls) at the valve!**  
**Hazard of crushing hands or feet and damage to valve or actuator.**

- End stops should be set by suitably qualified personnel only.
- Never completely remove the setting screws [2] and [4] to avoid grease leakage (refer to figure 4.8).

**Note:** The setting sequence for the end stops depends on the valve. We recommend to start with the end stop CLOSE for butterfly valves and with end stop OPEN for ball valves.

On delivery, unfasten both screws for the end stop (figure 4.7) to allow alignment of actuator to valve. The minimum and maximum dimensions for adjustment indicated in tables 4.3, 4.4 and 4.5 must not be exceeded. The valve must be in CLOSED position during actuator mounting.

Type of actuator 90°	Mid position a	Max.	Min.
DP30, 59,119 Ex	11 mm	14 mm	8 mm
DP319, 799 Ex	35 mm	40 mm	31 mm
DP1599 Ex	40 mm	46 mm	35 mm

Table 4.3: Setting limits of hexagon and pin-shaped stop screws with lock nuts

Type of actuator 90°	Mid position a	Max.	Min.
DP319, 799 Ex	3.5 mm	8.5 mm	-0.5 mm
DP1599 Ex	3 mm	9 mm	-2 mm

Table 4.4: Setting limits of pin-shape stop screws without lock nut

Type of actuator 90°	T	T <sub>min</sub>
DP75/150/299 Ex	17mm	11mm
DP300/450 Ex	20mm	12mm
DP600/900 Ex	23mm	13mm
DP1200/1800 Ex	23mm	12mm

Table 4.5: Setting limits of stop screws for planetary gearings

**The end stop screws are mechanical limits for manual operation and may not be approached during motor operation!**

Turn handwheel clockwise to mechanical stop, then slowly rotate one turn counterclockwise. The output drive plug sleeve must be fitted in the actuator. After finish boring, slide output drive plug sleeve on valve shaft and secure if required.

Apply a thin film of sealing agent (e.g. Curil K2) at output mounting flanges prior to assembly. Align actuator to the possible angle steps and slowly push on output drive plug sleeve.

In case the dog of the hollow shaft does not engage into the respective keyway of the output drive plug sleeve, rotate the handwheel until hollow shaft engages. Slowly rotate handwheel until flange bores align, then fasten actuator using flange screws. If more than one handwheel turn is required, put the actuator to the initial position, lift it and place it again onto the output drive plug sleeve by moving one indent.

## Setting the mechanical end stop screws

DP . . 30/59/119 (without gearbox) /319/799/1599 (with spur gearbox)

The actuator is in the respective end position. This position must match the valve end position. Insert and turn stop screw for the respective end position (figure 4.7) until resistance is felt. Then rotate by one turn in the opposite direction and secure with lock nut.

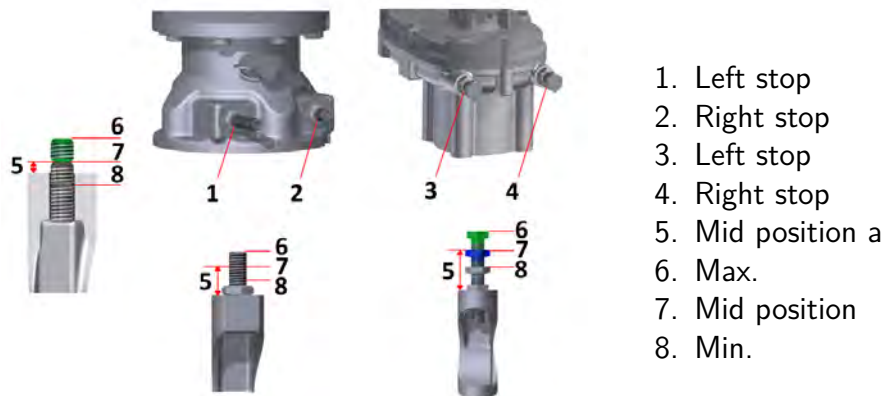

Figure 4.7: End stop screws

Slightly open valve by approximately half a turn of the handwheel (for end position CLOSED) or slightly close (for end position OPEN). Then perform end stop setting.

### Setting end stop CLOSED

1. Move valve to end position CLOSED with handwheel.
2. If the valve end position is not reached:
  - Slightly turn setting screw [2] or [4] counterclockwise until valve end position CLOSED can be correctly set.
  - Turning the setting screw [2] or [4] clockwise decreases the swing angle.
  - Turning the setting screw [2] or [4] counterclockwise increases the swing angle.
3. Turn setting screw [2] or [4] clockwise until end stop is reached, then turn in opposite direction by one turn.
4. Secure setting screw [2] or [4] with lock nut.

Now, end stop CLOSED setting is complete and end position CLOSED setting can be performed. Having completed this procedure, end stop OPEN can be immediately set.

### Setting end stop OPEN

1. Move valve to end position OPEN with handwheel.
2. If the valve end position is not reached:
  - Slightly turn setting screw [1] or [3] counterclockwise until valve end position OPEN can be correctly set.
  - Turning the setting screw [1] or [3] clockwise decreases the swing angle.
  - Turning the setting screw [1] or [3] counterclockwise increases the swing angle.
3. Turn setting screw [1] or [3] clockwise until end stop is reached, then turn in opposite direction by one turn.
4. Secure setting screw [1] or [3] with lock nut.

### Setting the mechanical end stop screws

#### DP. . . (R)75-1800 (with planetary gearing)

**Note:** The setting sequence for the end stops depends on the valve. We recommend to start with the end stop CLOSE for butterfly valves and with end stop OPEN for ball valves.

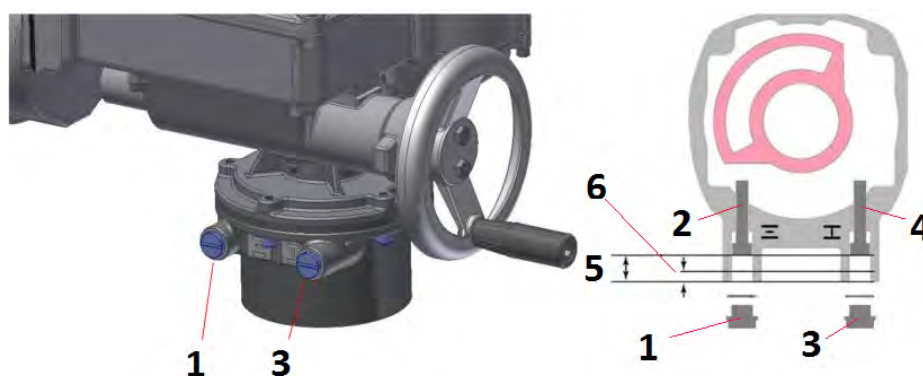

1. Screw plug for end stop OPEN
2. Setting screw for end stop OPEN
3. Screw plug for end stop CLOSED
4. Setting screw for end stop CLOSED
5. T
6.  $T_{\min}$

Figure 4.8: Cross section of compartment for end stop screws

### Setting end stop CLOSED

1. Remove screw plug [3].
2. Move valve to end position CLOSED with handwheel.
3. If the valve end position is not reached:
  - Slightly turn setting screw [4] counterclockwise until valve end position CLOSED can be correctly set.
  - Turning the setting screw [4] clockwise decreases the swing angle.
  - Turning the setting screw [4] counterclockwise increases the swing angle.
4. Turn setting screw [4] clockwise until end stop is reached, then turn in opposite direction by one turn.
5. Check O-ring in screw plug and replace if damaged.
6. Fasten and tighten screw plug [3].

Now, end stop CLOSED setting is complete and end position CLOSED setting can be performed. Having completed this procedure, end stop OPEN can be immediately set.

### Setting end stop OPEN

1. Remove screw plug [1].
2. Move valve to end position OPEN with handwheel.
3. If the valve end position is not reached:
  - Slightly turn setting screw [2] counterclockwise until valve end position OPEN can be correctly set.
  - Turning the setting screw [2] clockwise decreases the swing angle.
  - Turning the setting screw [2] counterclockwise increases the swing angle.
4. Turn setting screw [2] clockwise until end stop is reached, then turn in opposite direction by one turn.
5. Check O-ring in screw plug and replace if damaged.
6. Fasten and tighten screw plug [1].

Now, end stop OPEN setting is complete and end position OPEN setting can be performed.

## 5 Electrical connection

This section deals with the electrical connection of DREHMO actuators. Safety-related aspects, information on installation and modification of electrical connection are presented.

### 5.1 Important notes

**DANGER****Explosion hazard for installation in explosive areas!**

- Before opening, ensure that there is no explosive gas and no voltage.

**DANGER****Risk of direct contact with open live parts**

- The electrical connection must be carried out exclusively by suitably qualified personnel.
- Prior to connection, observe basic information contained in this chapter.
- Connection to electrical voltage is only permitted if all housing covers are appropriately closed! All housing parts must be free of damage!

**DANGER****Damage to flameproof enclosure (Explosion hazard!!)**

- Covers and housing parts must be free of damage
- Flameproof joints must neither be damaged nor soiled in any way
- Do not jam cover during fitting



Work on the electrical system or equipment and electrical installation work on actuators must only be carried out by skilled electricians themselves or by specially instructed personnel under the control and supervision of such an electrician and in accordance with the applicable electrical engineering rules.

Actuator installation and operation must additionally be in compliance with IEC/EN 60079-14 for gas explosive atmospheres.

The following points must also be observed:

- Observe indications on name plate
- Compare mains voltage
- Actuator is connected in compliance with the terminal plan supplied.  
Should the terminal plan not be available, please request another copy from the manufacturer indicating the device number.
- It is recommended to select shielded actuator connecting cables with the exception of the main power supply, to ensure actuator EMC.
- Since DREHMO actuators can be operated with separately mounted controls, the connecting cables between actuator and controls must be selected as shielded versions.
- For cable glands (including plugs!) make sure that the required IP enclosure protection is guaranteed and suitable for connecting cables.
- The connecting cables must comply with the requirements in terms of electrical connection data and load (mechanical, thermal and chemical).
- All actuators must be equipped with appropriate fuses for cable protection. Fuse specification must be calculated on the basis of published motor data.

**In addition, the following points must be observed for explosion-proof actuators.**

- According to IEC/EN 60079-14, actuators and the pertaining switching and distribution devices have to be considered within the framework of the protective actions for the connected mains.
- Motor winding protection is ensured with PTC thermistors according to DIN 44082 and a certified tripping device tested for perfect function.
- If the actuator is to be used in explosion-proof atmospheres, cable glands and plugs with appropriate certification must be used for the respective application.
- Electrical connection of explosion-proof actuators is exclusively made via appropriately certified connection terminals in compliance with the terminal plan supplied.
- To ensure required equipotential bonding, actuators must be connected via the outer earth terminal to the equipotential compensation system, provided that no fixed and secured metallic contacts with construction parts are available which are in turn connected to the equipotential compensation system.

DREHMO actuators are not equipped with an internal protective device against failures within the power circuit.

**DANGER****Impermissible heating up of the motor (Explosion hazard!)**

- Any protective measures have to be provided at plant level.
- When using an electronic load relay, the third phase is always connected with the motor. Consequently, there is a risk of motor overheating in case of fault. This can be prevented by all-pole disconnection of the actuator.

**DANGER****Loss of explosion protection**

- If not ordered otherwise the actuator is supplied with non Ex-certified blanking plugs. They have to be replaced prior to commissioning by appropriate cable glands to maintain explosion protection.

**DANGER****Hazardous voltage while protective earth conductor is NOT connected! Electric shock possible.**

- Connect all protective earth conductors (if required use external earthing screw).
- Power the device only once the protective earth conductor has been connected.

## 5.2 Connection terminals

Different versions are available for actuator connections. Refer to chapter 9 for precise indications relating to possible cable cross sections and, if applicable, pertaining tightening torques.

### 5.3 Opening the pluggable electrical connection

The explosion proof DREHMO actuators can be equipped with a pluggable electrical connection (refer to figure 5.1).

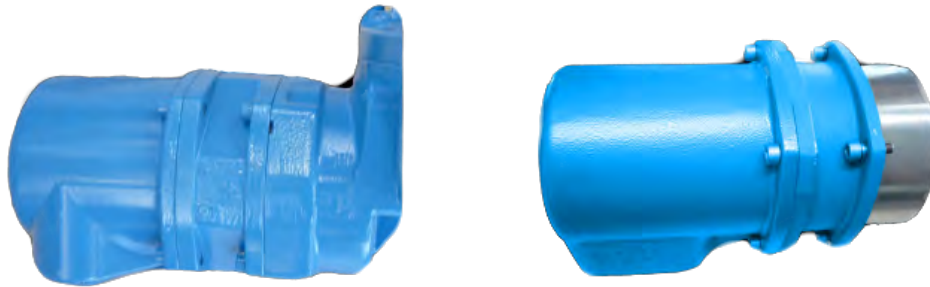

Figure 5.1: pluggable part of the electrical connection

The pressure proof encapsulation of the actuator will be disabled by disconnection of the electric connection. Therefore it is only permitted to open the actuator if the environment is free of gas and oil. Additionally it must be ensured that the plug of the actuator is de-energised (power and signal cables). It is not allowed to connect power to the plug, if a parking socket without a certification for explosive atmospheres is used. This holds for the power connections as well as for the auxiliary voltage or possibly the BUS wires.

#### **DANGER**

**Loss of explosion protection if pressure proof encapsulation is opened**



- There is no voltage allowed on the plug when the encapsulation is opened.
- The auxiliary voltage or possibly the BUS wires must be de-energised too.

# 6 Local controls

The actuators are equipped with local controls containing the graphic display and display elements for local control or menu operation as well as a wireless parameterisation and diagnostic access via infra-red (IR) or Bluetooth (BT) technology. The definite version of display unit with display screen at the actuator can differ with reference to interface, display elements and display version (refer also to 6.1).

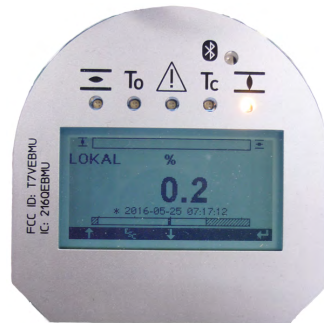
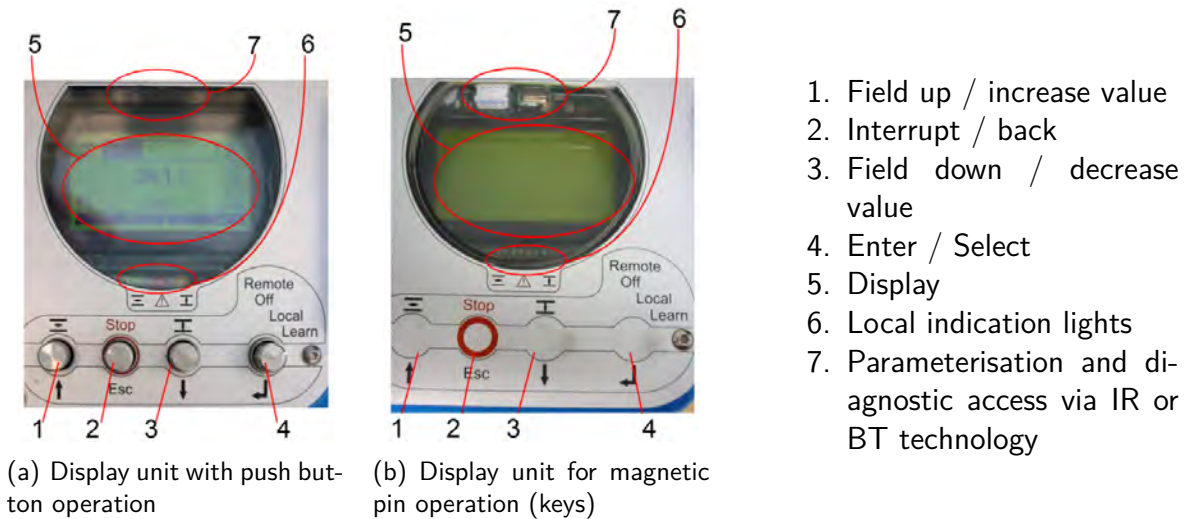

(c) Display version 2  
(only with bluetooth interface)

Figure 6.1: Version of local controls

## 6.1 Local indication lights

These indication lights are used to display certain actuator states. Depending on configuration, both outer indication lights are used for signalling directional running indications or reaching an end position. The mid indication light is reserved as failure signal. The nature of the indicated failure can be set via actuator controls parameterisation. Please refer to the firmware description for exact procedure and available options.

## 6.2 Operation

After booting of actuator controls, the basic screen is displayed with the most important details like position, torque, type of duty and if available fieldbus status as well as any imminent failures or warnings. Data structure can differ depending on firmware and hardware.

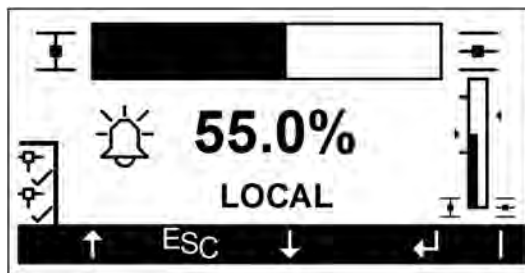

(a) Display version 1

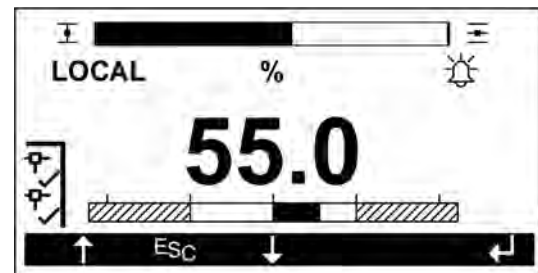

(b) Display version 2 or display version 1 as IMC-version

Figure 6.2: Basic display screen after system start

Local control is performed via four operating elements, either as mechanically operable spring-loaded push buttons (6.1 a) or as hidden magnetic keys (6.1 b). For operation, magnetic keys require a special magnetic pin available as separate accessory.

Standard functional assignment of push buttons/keys is indicated on the provided face plate of local controls. Furthermore, the lower display status indication shows the current function assignment which might vary depending on sub-menu operation.

If LOCAL or LEARN are displayed, actuator operation can be performed using the arrow push buttons (1 and 3 refer to figure 6.1). This is not possible if the display indicates OFF or REMOTE.

If the lock symbol is displayed (refer to figure 6.3), local operation is disabled and the actuator can only be operated from REMOTE. In this instance, an enable command must be issued to activate use of local controls. If local controls are not disabled, select the menu for operation mode LOCAL by means of the ENTER push button/key (4 in figure 6.1).

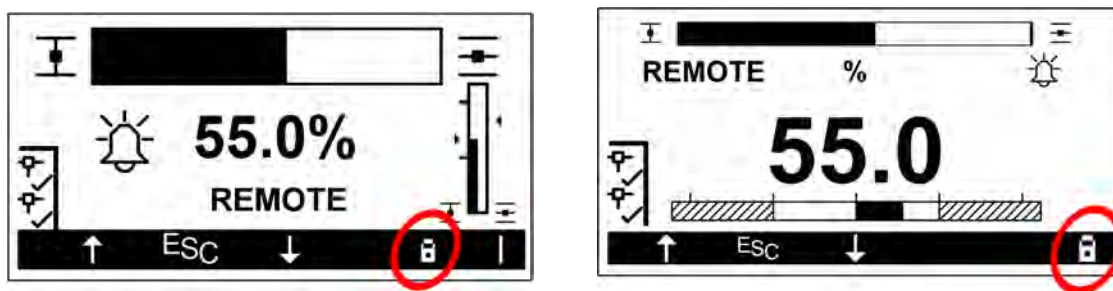

Figure 6.3: Display unit disabled

If one or several faults are signalled, a message appears whether the fault is to be displayed. This request can be acknowledged via ESC push button/key (2 in figure 6.1) which brings you back to the main menu where you can change operation mode or proceed with parameter setting.

The arrow push buttons/keys (1 and 3 in figure 6.1) are used for scrolling through the menu group selections and the individual menu items. When entering a parameter, the two push buttons are used to change the parameter or a character of the parameter (e.g. for text fields).

The ENTER push button/key (4 in figure 6.1) is used to enter the selected menu group or to terminate the entry. When entering parameters consisting of several characters, use the ENTER push button/key to go to the next character. Text entry is terminated by pressing again the ENTER push button/key after the last text character (always one space).

The ESC push button/key is used to go from one menu group to the next higher level. When entering a parameter, this push button/key is used to interrupt the entry without saving. When entering parameters consisting of several characters, use the ESC push button/key to go back to the last character. When pressing the ESC push button/key and the cursor is still on the first character, the entry is terminated without saving the newly entered value.

Messages can always be displayed during actuator operation. A fault message during operation always requires acknowledge with ENTER push button/key prior to resuming operation!

The following fault messages are possible:

- To edit this parameter, you require user level x  
Remedy: Sign in at the required user level x
- The new value must be between Limit 1 and Limit 2!  
Remedy: Enter a new value for the parameter within the permitted range.
- Parameters can only be edited in operation modes OFF and LEARN! Now switch to operation mode OFF?  
Remedy: When acknowledging with ENTER, the actuator is directly changed to operation mode OFF.
- This parameter cannot be edited!

### 6.3 Access protection of local controls

Access of local controls can be controlled either by mechanical locking of local controls or by implementing software access protection. The respective actuator functions can be locked with the conventional customer user levels: Nobody, User, Maintenance. If password protection is already activated for the user, the actuator cannot be operated without entering the correct password.

Mechanical locking of local controls in combination with mechanically operable spring-loaded push buttons is as follows:

The ENTER push button (4 in figure 6.1) can be locked with appropriate conventional padlocks (lock diameter maximum 3 mm) to prevent changing the operation mode. Depending on the requirement, individual keys and padlock systems can be supplied while indicating the number of keys per padlock (DREHMO order number 143429, 148180 for packlock systems).

### 6.4 Language selection

For language selection, please proceed as follows:

1. Set operation mode to OFF.
2. Navigate to menu item LANGUAGE.
3. Activate parameter for editing via ENTER push button/key.
4. Use push buttons 1 and 3 (in figure 6.1) to select the desired language.
5. Confirm with the ENTER push button/key.
6. The selective language is immediately activated!

Please contact our service if the required language is not available in your actuator.

From software version *V01.06.0080* (IM; IMC all software versions), a temporary language modification can be performed from the basic screen (which is automatically reset after next system start) by holding down the ESC push button/key for approx. 5 seconds, followed by acknowledgement of the language change (always to English) by pressing the ENTER push button/key. For permanent language selection, please use the configuration as indicated above.

## 6.5 Display elements

After switching on, the main screen is displayed and all local indication lights (refer to number 6 in figure 6.1) and activated for approx. 3 seconds. During operation, the main data is shown in the display as indicated in figure 6.4.

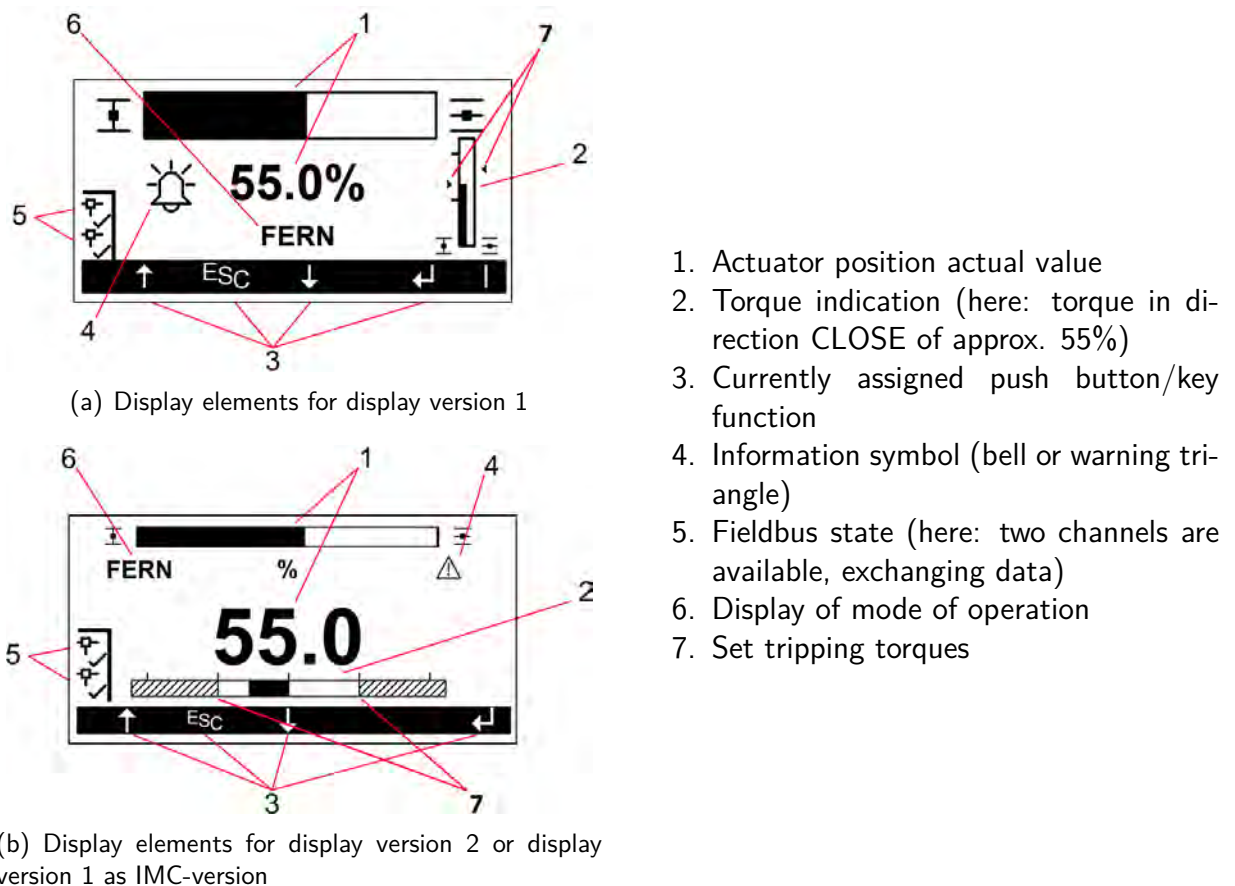

Figure 6.4: Display elements

Actuator position is displayed as bar graph and in figures according to the configured position unit (1 in figure 6.4). As standard, end position CLOSED corresponds to a position of 0 % (bar completely empty) and end position OPEN to 100 % (bar completely filled).



The applied torque is shown at the right margin of the screen for IM version (2 in figure 6.4 a) and for IMC version below the actuator value display (2 in figure 6.4 b). This indication element represents two different details:

1. the current torque
2. the set tripping torques

The bar at the lower screen visualises the current function assignment of push buttons/keys (3 in figure 6.4). Actuator operation mode is either indicated in mid display (2 in figure 6.4 a) or top left (2 in figure 6.4 b).

Type of duty	Description
OFF	The actuator can no longer be controlled neither from LOCAL nor from REMOTE ( <b>CAUTION:</b> The ESD command can be programmed as to ignore operation mode OFF).
LOCAL/ LOCAL OFF	The actuator can only be controlled from LOCAL. Operation commands from REMOTE are not executed. REMOTE disabling of local controls can be performed via device parameterisation. Local control is then only possible if a digital enable signal is present from REMOTE. When selecting operation mode LOCAL without enable signal from REMOTE, the operation mode displayed on the screen in 6 <sup>th</sup> position in figure 6.4 is LOCAL OFF.
REMOTE	The actuator can only be operated via connected DCS. Operation commands via local controls are not executed. <b>CAUTION:</b> In combination with connection monitoring to DCS, unexpected actuator operations may occur within the framework of the actuator fail safe behaviour.
Force LOCAL	In this mode, external local controls can be simulated via the digital inputs at the actuator.
LEARN	Important commissioning functions are exclusively executed in this operation mode. The actuator can only be controlled from LOCAL. Operation commands from REMOTE are not executed. Emergency shut down function of actuator is inactive.

Table 6.1: Type of duty

The function force LOCAL is intended for simulating separately mounted local controls. In this case, the corresponding signals are given via the binary inputs.

Command	Description
Force LOCAL	The actuator is switched from the operating modes OFF, LOCAL, REMOTE to the operating mode force LOCAL. The feedback signal of the operating mode via fieldbus and parallel interface changes to operating mode LOCAL.
Force LOCAL OPEN / Force LOCAL CLOSE	Via inputs force LOCAL OPEN and force LOCAL CLOSE, the actuator can be operated in the corresponding direction during mode force LOCAL.
Force LOCAL STOP	If the signal force LOCAL STOP is assigned to an input, the inputs force LOCAL OPEN and force LOCAL CLOSE are used as self-retaining commands. Otherwise they are controlled by push-to-run mode. The parameter Maintain mode LOCAL is irrelevant for this operating mode. If the signal is activated, the actuator is stopped.

Table 6.2: Commands of the operation mode force LOCAL

**Note:** Commands enable LOCAL, enable OPEN and enable CLOSE remain active in operation mode force LOCAL.

**DANGER**

**Activation of emergency shut down in operation modes OFF and LOCAL.**

**These parameters are used to select actuator emergency shut down even if the actuator is set to operation modes OFF or LOCAL.**



- Prior to working at the actuator, check correct parameter setting.
- Heed that the emergency shut down command is not issued by mistake.

The display unit is completely locked. In this case, a lock is displayed instead of the ENTER symbol. If a fault is present in compliance with the current actuator configuration, a bell is displayed at position 4 in figure 6.4. Warnings are displayed at the same spot by means of a triangle with exclamation mark.

The bell indicated as number 4 in figure 6.4 a) or the warning triangle indicated as number 4 in figure 6.4 b) are used as information symbols. These faults can be parameterised. The pertaining parameters are listed in menu item **COLLECTIVE FAULT SIGNAL**. For further information on actuator parameterisation, please refer to the firmware description.

When using the fieldbus interface, the respective symbols are displayed at the left margin of the screen (5 in figure 6.4 a) and b) ). Used hardware detection and available redundancy recognition are automatic. Therefore, the display symbols differ depending on the fieldbus interface version. Depending on the detected hardware, the parameters for configuration of the respective fieldbus interface are available using menu item: **DCS / PLC SYSTEM → INTERFACE**. The menu item **ACTUAL VALUE/DIAGNOSIS → INTERFACE** is used to check the fieldbus interface status. For further information, please refer to the respective instructions on fieldbus interfaces.

## 6.6 Contrast setting

A change of the contrast can be performed from the basic screen. Therefore the button can be used together with the UP or DOWN button. The combination of the buttons ESC and UP increase the contrast. To decrease the contrast use the combination of the buttons ESC and DOWN.

## 6.7 Parameterisation and diagnostics interfaces

### Bluetooth

Actuators of type IM and IMC are equipped with a Bluetooth interface (refer to figure 6.6). For access, special parameters are available for identification and password protection. For using this feature, a DREHMO BT dongle in combination with the i-matic Explorer 2 software is required. The BT dongle is available as accessory. The Bluetooth interface further offers the access facility by means of a mobile application for Android operation systems. The DREHMO i-matic Explorer application is available with the Android App Store or in the Download area of the DREHMO website.

### IR interface

DREHMO actuators of IM type can be equipped with a local IR interface (refer figure 6.5). This interface is used to read and write parameters from and to the device. The IR interface is also used to load the firmware to the device. The i-matic Explorer 2 software and an IR adapter are required to use the IR interface. The IR-adapter is available as accessory. Please refer to the DREHMO download area on the website [www.drehmo.com](http://www.drehmo.com) for downloading i-matic Explorer 2.



#### **NOTICE**

##### **Safety risk by IR interface**

- It is advised to deactivate the IR interface if not used



#### **DANGER**

##### **Ignition risk of explosive substances caused by the IR interface**

- When using the IR adapter in potentially explosive atmospheres, make sure that no explosive substances are present.



### NOTICE

#### Activation/Deactivation via parameterising possible

- Access via Bluetooth or IR interface can be inhibited via parameterisation



### NOTICE

#### Access can be inhibited via DCS

- Access via interface can be inhibited via DCS
- The signal for inhibiting the interfaces can be configured as desired

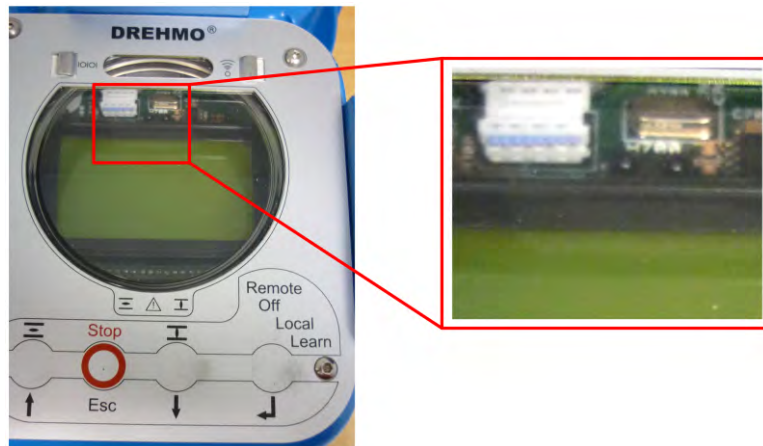
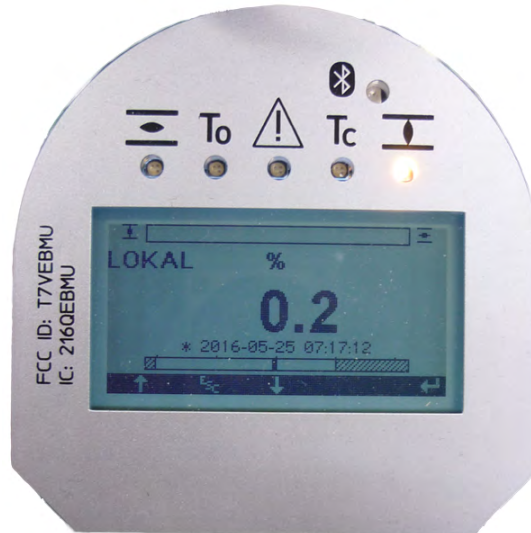

Figure 6.5: IR-Schnittstelle



(a) Display Version 1



(b) Display Version 2

Figure 6.6: Bluetooth-Schnittstelle

# 7 Commissioning



## WARNING

**Damage to electronics at temperatures below  $-25^{\circ}\text{C}$**

- The actuators may only be commissioned at temperatures above  $-25^{\circ}\text{C}$ .

For electronic commissioning, the following steps are required:

- Verification of actuator power supply and adapting the pertaining parameters as required.
- Valve specific basic settings like closing directions, tripping torques, end position settings, switch-off behaviour.
- Parameterisation for local display, local operation and DCS connections.

## DANGER

**Risk of immediate motor start when connecting the power supply**



- For conventional interfaces, link the STOP command to the respective actuator input (refer to terminal plan).
- For fieldbus interfaces, set the STOP command via the DCS.
- For fieldbus interfaces, do not apply automatic command.
- For actuator commissioning, set the actuator via COMMISSIONING selection into operation mode LEARN.
- Prior to disconnecting the actuator from the power supply, set the actuator to operation mode OFF.

## 7.1 Connection of the power supply

Prior to connecting the power supply, check if the supply complies with the name plate data and if the protection facilities are sufficient. Refer to menu item **PARAMETERS** → **POWER SUPPLY** for the respective parameters. Power supply adaptations can be performed via parameters **PHASE CORRECTION** and **PHASE MONITORING** if required.

The actuators are equipped with automatic phase sequence detection for 3-phase AC mains from 220 to 690 V. **Note: Risk of failure of automatic rotary field detection in presence of disturbed, asymmetric mains.** In this instance, the rotary field direction applied must be configured as available. For 1-phase DC supplies or 1-phase AC supplies, the **clockwise rotary field** must be configured.

Phase failure monitoring is used to monitor the individual phases and issue a signal in case of failure. This parameter must be set to **Deactivated** when working in 1-phase AC or 1-phase DC supplies. For verification purpose, the values measured can be checked in menu item **ACTUAL VALUE/DIAGNOSIS** → **POWER SUPPLY**. For further information, please refer to the firmware.

**DANGER**

**Risk that output drive torque of actuator exceeds the max. permissible input torque of gearbox/linear thrust unit or valve**



- Check whether the actuator output torque falls below the max. permissible input torque of gearbox/linear thrust unit or valve.
- If required, imperatively adapt the specifications in the electronic name plate.



## 7.2 Valve-specific basic settings

For actuator commissioning, select actuator mode **Commissioning**. To activate Commissioning mode, user level **Maintenance** is required. Please refer to the separate firmware description for the listing and explanation of the different user levels available. Then, the message appears as shown in figure 7.1 is displayed:

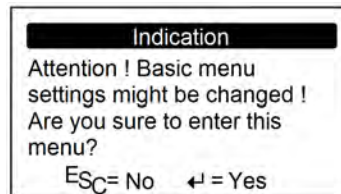

Figure 7.1: Display indication 1

Acknowledgement via ENTER push button/key generates the screen as shown in 7.2:

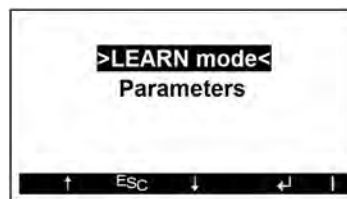

Figure 7.2: Display indication 2

At this level, you may either select the actuator Commissioning menu or the actuator Parameters menu. In a first step, the valve specific parameters can be checked and adapted if required such as: final positions, closing direction, type of seating and torques.

Please refer to the separate firmware description for details on the individual parameters. During motor operation (when leaving the final positions OPEN or CLOSED), it might be required to activate the torque by-pass in the end positions, should the unseating torque in opposite direction exceed the set tripping torque. Commissioning can be performed via the commissioning menu once the previous steps are complete.

In a next step, proceed with final position setting of the respective actuator. On delivery,

**WARNING****Damage to valve**

- Observe the valve-specific requirements for the respective end position seating.

the actuator is set to 50 % of the preset travel with  $\pm 90$  actuator output drive turns. To reach a final position outside the preset range, first operate to the preset final position. Then delete this position. Consequently the final position is shifted by 90 turns in direction of the respective direction. This extension of the preset range has to be repeated if required until the desired final position is reached. The maximum travel which can be set between OPEN and CLOSE is 1,440 actuator output drive turns.

**Setting final position CLOSE**

As standard, the actuator is mounted onto a valve in end position CLOSE. We recommend setting this end position first. Proceed in compliance with the following step sequence:

1. Navigate to and select menu item **COMMISSIONING**.
2. Navigate to the menu item **CHANGE FINAL POSITIONS**.
3. Via item **DELETE FINAL POSITION CLOSE**, the setting can be reset to the default value.
4. Select the sub-item **SET FINAL POSITION CLOSE**. In this item, the actuator can be motor operated to the final position (both directions are possible for operation).
5. Confirm the final position setting.
6. Briefly operate actuator out of final position CLOSE using the display unit.
7. Check limit seating on reaching the final position when returning into final position CLOSE.
8. If required, correct actuator position and repeat steps 2 through 7.

### Setting end position OPEN

If final position CLOSED is set, proceed with final position OPEN setting. Proceed in compliance with the following step sequence:

1. Navigate to and select menu item **COMMISSIONING** (if not already selected).
2. Navigate to the menu item **CHANGE FINAL POSITIONS**.
3. Via item **DELETE FINAL POSITION OPEN**, the setting can be reset to the default value.
4. Select the sub-item **SET FINAL POSITION OPEN**. In this item, the actuator can be motor operated to the final position (both directions are possible for operation).
5. Confirm the final position setting.
6. Briefly operate actuator out of final position OPEN using the display unit.
7. Check limit seating on reaching the final position when returning into final position OPEN.
8. If required, correct actuator position and repeat steps 2 through 7.

**If torque seating is required in one of the two directions, the final positions must be selected prior to reaching the tripping torque.**

### Manual adaptation of analogue position signal

After having set both final positions, the 4 to 20 mA signal is automatically adapted to the travel setting. Readjustment of the analogue signal in menu items Value 0% and Value 100% can be performed if higher precision is required.

## Checking the torque values

DREHMO actuators type i-matic are delivered at minimum adjustable tripping torque, if not stated otherwise on the order. If adaptation is required, make sure that the actuator is switched to OFF. Then proceed as described below:

1. Navigate to the menu item **Parameters**.
2. Select sub item **Valve**.
3. Select tripping torque OPEN or CLOSE.
4. Set the required value by means of arrow push buttons.
5. Confirm with ENTER.
6. Check the sub items **WARNING TORQUE OPEN** and **WARNING TORQUE CLOSE**. (They must not exceed the tripping torques!)
7. Select warning torques to be modified.
8. Set the required value by means of arrow push buttons.
9. Confirm with ENTER.

The values to be set can be controlled and adapted if required in **PARAMETERS** → **VALVE**. Please refer to the separate firmware descriptions for details on all setting options.

## Internal positioner and stepping mode

The actuator can be equipped with an internal positioner. The availability of the internal positioner is registered in the electronic name plate. Positioner activation is made via an external signal or set by means of parameterisation. Both positioner function and stepping mode are available. For using this function, adaptation of special parameters in **PARAMETERS** → **PROCESS** is required.

For modulating applications, the permissible frequency in numbers of starts may not be exceeded. Limit values can be defined in **OPER. DATA AQUISITION** → **OPERATION DATA**. This data is monitored during active operation and fault indications are generated if applicable.

## Reversing delay

Significant motor overrun is detected under weak load or no load. When changing the direction of rotation of the motor during overrun, current peaks might occur risking to damage the power unit. For motor and power unit protection, it is possible to set a reversing delay between 0.4s to 3s within the integral electronics. If the actuator is equipped with a brake motor, reversing delay of 0.4s is sufficient, provided the actuator load amounts to minimum 15% of the rated torque. Otherwise, the delay time can last up to 2s. Sufficient off times must be ensured by the plant operator to avoid any power unit damage. Imperatively respect the operation mode of the respective actuator!

### 7.3 Parameter setting

Unless indicated otherwise, all i-matic actuators are supplied with default parameter assignment. Please refer to separate firmware documentation for default parameter assignment. On request, the actuator can be supplied with customer-specific parameter assignment. The actuator parameter assignment is saved at the manufacturer's as factory setting and can be requested with the service department if required.

For actuators with fieldbus, changes can be performed via the respective fieldbus interface if required. For details on fieldbus interfaces, please refer to the pertaining operation instructions. Specific parameterisation tools or fieldbus-specific drivers (Electronic Device Description - EDD, Device Type Manager - DTM) can be downloaded from the [DREHMO](#) website or are available on request.

### 7.4 Fault indications

The actuator permanently monitors both data and hardware. Exceeding limit values as well as electronics errors can be issued as separate indications. Furthermore, two collective fault signals are available whereby collective signal 1 represents errors and collective signal 2 represents warnings. Collective fault signals can be configured in menu item **DCS / PLC system**. Indications are recorded in the error log as pending errors. For details, please refer to the firmware description.

# 8 Servicing and maintenance

In this section, information is given to be observed when maintaining, cleaning or disposing of DREHMO actuators.

## 8.1 Maintenance

We recommend participation in the regular trainings for performing maintenance tasks. Basic special knowledge in electrical installation and mechanical engineering is sufficient (in Germany: industrial training - apprenticeship). Permitted maintenance work:

- Replace handwheel
- Replace output drive
- Check oil level

Before further use of the actuator, make sure it is reset to original condition.



### **DANGER**

**Explosion hazard for explosion-proof version, due to incorrect repairs of the flameproof joints**

- Only the manufacturer is allowed to do repairs of the flameproof joints



### **NOTICE**

**Excessive lubricant application can impair the tightness of the actuator**

- The actuators have a lifetime lubrication
- A device for permanent lubrication of a stem (only output drive type A and A-HP) can be inquired of the manufacturer

Correct commissioning is a prerequisite for reliable actuator operation. We recommend to checking the fixing screws between actuator and valve or gearbox for tightness once a year.

## 8. SERVICING AND MAINTENANCE

Open-close actuators must be checked for wear after a cumulated operating time of 150 hours, modulating actuators however at the latest after  $10^6$  starts! For safe and reliable service, we recommend - especially if infrequently operated - performing a test run every 6 months. Apply a thin film of Molykote 165 LT to the threads of unfastened housing screws prior to refastening. Apply a thin film of Klüber Isoflex Topas NB5051 to the sealing joints between the housing parts.

Actuator controls issue supporting information for maintenance in menu item **Oper. data acquisition**. The so-called dynamic maintenance indications refer to basic actuator information.

For technical queries, please contact our service department, always stating your device number (This number is indicated on the actuator name plate). Overhauling defective actuators is only permitted in the factory or with an authorised service centre.

### 8.2 Troubleshooting and corrective actions

After maintenance, perform functional tests in compliance with operation instructions. Commissioning of actuator/valve must be performed if tripping parameters, valve or additional gearing have been changed.

### 8.3 Oil filling

The actuator oil filling is specified for the actuator lifetime. It is indispensable part of the non electrical explosion protection of the device. For this reason, only oils approved by DREHMO GmbH may be used for the actuators. The actuators are filled with oil for ambient temperatures of  $-25^{\circ}\text{C}$  to  $+60^{\circ}\text{C}$  according to table 8.1.

Actuator type	Oil quantity [l]	Oil type
DPiM 30/59/119 Ex	1.6	Shell Tellus S2 VX 15
DPiM 319/799/1599 Ex	1.6	Shell Tellus S2 VX 68
DPiM 75/150...1800 Ex	1.6	Shell Tellus S2 VX 68
DiM /DiMR 30/59 Ex	1.6	Shell Tellus S2 VX 68
DiM /DiMR 60/120/249 Ex	2.6	Shell Tellus S2 VX 68
DiM /DiMR 250/500/1000 Ex	3.2	Shell Tellus S2 VX 68
DiM 2000 Ex	9	Shell Omala S2 G 100

Table 8.1: Oil filling

The oil filling may differ for other temperature ranges. If required, please contact the manufacturer for appropriate data. Tight sealing of the device must be checked at appropriate intervals during scheduled inspections. Particular attention must be paid to following parts:

- Oil leakage at handwheel hub
- Oil leakage at joints of the housing
- Oil leakage at seals of hollow shaft

**DANGER**

**Impermissible heating up of actuator by oil leakage (Explosion hazard!)**

- Seals must be replaced in case of leakage.
- Make sure to refill to the correct oil level.

## 8.4 Cleaning

Clean the actuator using conventional soap solutions (alkaline solutions). To prevent heat accumulation or excessive surface temperatures, make sure that the motor cooling fins are never covered.

**The warning references on the device may not be removed or covered with color!**

**DANGER**

**Electrostatic discharge (Explosion hazard!)**

- All outer actuator parts e.g. painted surfaces, indicator glass, labels, etc. may only be cleaned using a moist cloth.
- The device must be equipped with appropriate labels which must be readable at all times!

**DANGER**

**Impermissible heating up by paint coating (Explosion hazard!)**

- It is not permitted to repaint the actuator!





### NOTICE

#### Residues of conductible foreign particles within the actuator

- Use of compressed air for cleaning the actuator is not permitted!

Use of any cleaning agents within the actuator is not permitted. Any contamination may be removed using lintless cloths free of any contamination. Use of compressed air is not permitted.

## 8.5 Disposal

During decommissioning and disassembly of actuators, please observe any potential installation-specific hazards. If required, appropriate disposal can be offered by the manufacturer. Actuators can easily be separated and sorted according to materials used:



- electronic scrap
- various metals
- plastics
- greases and oils

The following generally applies:

- Generally, greases and oils are hazardous to water and must not be released into the environment.
- Arrange for controlled waste disposal of the disassembled material or for separate recycling according to materials.
- Observe the national regulations for waste disposal.

## 9 Technical data

This section comprises the summary of all technical data of DREHMO actuators described in these instructions.

### 9.1 Contact and water protection

The type of enclosure protection (IPxx) is indicated on the actuator name plate. In standard version, the actuator is suitable for outdoor installation and completely protected against dangerous contact, ingress of dust and ingress water for temporary immersion in water (enclosure protection IP67 in compliance with IEC/EN 60529 Further IP enclosure protection types are available on request as options. Enclosure protection IP68 is available as option. This enclosure protection protects against ingress of water for immersion up to 5 m for 24 hours.

**DANGER**  
**Risk of deviating IP enclosure protection**



- Ensure use of correct cable glands.
- Unused cable entries must be sealed using appropriate blanking plugs.
- If the actuator has a K5 corrosion protection, ensure use of plastic cable glands to prevent damage of the protecting cover.

**DANGER**  
**Explosion hazard caused by incorrect cable glands and cable entries!**



- If the actuator is to be used in explosion-proof atmospheres, cable glands and plugs with appropriate certification must be used for the respective application.

**NOTICE****Damage to the display unit by direct sunlight**

- Protect the display unit from direct sunlight and temperatures above 85 °C

**DANGER****Impermissible heating up of actuator by direct sunlight (Explosion hazard for explosion-proof version!)**

- Make sure to regard the permissible operation temperature of the actuator when it is exposed to direct sunlight (use shadowing if necessary)

## 9.2 Overview Technical data

Rated voltage	Refer to indications on motor name plate in V $\pm 5\%$
Rated current	Refer to indications on motor name plate in A
Mains frequency	Refer to indications on motor name plate in Hz $\pm 2\%$
Rated power	Refer to indications on motor name plate in kW
Insulation strength	Overtoltage class II according to EN 61010-1
Electrical connection	The cable cross section can be calculated on the basis of motor data, the cable length and regional regulations!
	<i>Compact plug/socket connectors</i> $\varnothing 100$ mm: (connectable cable cross sections) Signal cables: 0.75 mm <sup>2</sup> – 1.5 mm <sup>2</sup> /1 Nm tightening torque Power cables: (1.5) <sup>1</sup> 2.5 mm <sup>2</sup> – 6 mm <sup>2</sup> /2 Nm tightening torque

<sup>1</sup>with little clamping disc

	<p><i>Terminal compartment in Ex e:</i> Refer to table 9.1 for available cable cross sections as well as pertaining tightening torques.</p>
Fuses	<p><i>F4 / F5 to 500 V:</i> Glass tube safety fuse 500 V/ M 1.25 A M=medium-blow Size 5×30 mm</p> <p><i>F6/F7 :</i> Glass tube miniature fuse 250 V/ T 1.6 A T=slow-blow Size 5×20 mm Blow characteristics slow-blow in compliance with IEC60127-2/3</p> <p>Version IMC instead <i>F7</i> use <i>F3</i>: subminiature fuse 250 V/ T 1 A T=slow-blow</p>
Contact rating (resistive load) Overvoltage category I	<p>Output contacts electrical version IM: max. 230 V AC 0.3 A, 30 V DC 2 A</p> <p><i>Gold plated contacts:</i> Voltage: 5 bis 30 V; current: 4 to 400 mA; <math>U \cdot I \leq 0.12 \text{ VA}</math> Optional output contacts (monostable and bistable): max. 220 V DC 0.3 A, 30 V DC 2 A</p> <p>Output contacts electrical version IMC: max. 240 V AC 0.25 A, 30 V DC 2 A</p>
Electrical load	$\leq 300 \Omega$
Motor temperature class	Refer to indications on motor name plate
Explosion protection	ATEX type examination certificate or IECEx Certificate of Conformity. For respective marking, refer to name plate
Ambient temperature range	Refer to indications on motor name plate in °C
Enclosure protection	Refer to indications on name plate
Pollution degree	Inside the actuator: pollution degree 1 (IEC 60664-1) Outside the actuator: pollution degree 2

### Vibrations

The actuators are designed for vibrations in the range between 10–100 Hz with an amplitude of 2g (with high transition frequency according to EN 60068-2-6).



### **DANGER**

**Lower cooling capacity if used at altitudes > 2000 m above sea level (Explosion hazard!)**

- Please contact manufacturer when exceeding this value since restrictions with regard to load capacity and isolation occur for identical ambient temperature.

### 9.3 Permissible terminal compartment

Manufacturer	Designation	Cross sections	Dismantling	Torque
Weidmüller	WDU 4N	1) 0.5 – 6 mm <sup>2</sup> / 1.5 – 6 mm <sup>2</sup> 2) 0.5 – 4 mm <sup>2</sup> / 0.5 – 4 mm <sup>2</sup>	11 mm	0.5 – 1.0 Nm
Weidmüller	WPE 4N	1) 0.5 – 6 mm <sup>2</sup> / 1.5 – 6 mm <sup>2</sup> 2) 0.5 – 4 mm <sup>2</sup> / 0.5 – 4 mm <sup>2</sup>	10 mm	0.5 – 1.0 Nm
Wago	264-120	0.5 – 4 mm <sup>2</sup>	8 – 9 mm	Label of handling
Wago	264-220	0.5 – 4 mm <sup>2</sup>	8 – 9 mm	Label of handling
Phoenix	MXK4	1) 0.2 – 4 mm <sup>2</sup> / 0.2 – 4 mm <sup>2</sup> 2) 0.2 – 4 mm <sup>2</sup> / 0.25 – 2.5 mm <sup>2</sup>	8 mm	0.6 – 0.8 Nm
Phoenix	MSLKG 5	1) 0.2 – 4 mm <sup>2</sup> / 0.2 – 4 mm <sup>2</sup> 2) 0.2 – 4 mm <sup>2</sup> / 0.25 – 2.5 mm <sup>2</sup>	8 mm	0.6 – 0.8 Nm
Phoenix	MBK 3/E-Z	1) 0.2 – 4 mm <sup>2</sup> / 0.2 – 4 mm <sup>2</sup> 2) 0.2 – 2.5 mm <sup>2</sup> / 0.25 – 1.5 mm <sup>2</sup>	8 mm	0.6 – 0.8 Nm
Phoenix	USLKG 10N6	1) 0.5 – 16 mm <sup>2</sup> / 0.5 – 16 mm <sup>2</sup> 2) 0.5 – 10 mm <sup>2</sup> / 0.5 – 6 mm <sup>2</sup>	10 mm	1.5 – 1.8 Nm
Phoenix	UK 10 N	1) 0.5 – 16 mm <sup>2</sup> 2) 0.5 – 10 mm <sup>2</sup> / 0.5 – 6 mm <sup>2</sup>	10 mm	1.5 – 1.8 Nm

Table 9.1: Connection terminals

- 1) solid wire / stranded
- 2) fine stranded / fine stranded with wire end sleeve

## 9. TECHNICAL DATA

The following table 9.2 lists the weights, the output drive speeds and the maximum modulating torques of the actuators.

Type of actuator	Output drive speed / operating time	Maximum modulating torque	Average weight in kg
DiM 30 Ex	5 – 160	15	23
DiMR 30 Ex	5 – 40	15	23
DiM 59 Ex	5 – 50	30	25
DiM 59 Ex	80 – 160	30	25
DiMR 59 Ex	5 – 40	30	25
DiM 60 Ex	5 – 160	30	29,5
DiMR 60 Ex	5 – 40	30	29,5
DiM 120 Ex	5 – 160	60	33,5
DiMR 120 Ex	5 – 40	60	33,5
DiM 249 Ex	5 – 50	125	33,5
DiM 249 Ex	80	125	33,5
DiM 250 Ex	5 – 50	125	69,5
DiM 250 Ex	80 – 160	125 <sup>1</sup>	69,5
DiMR 250 Ex	5 – 40	125	69,5
DiM 500 Ex	5 – 80	250	80,5
DiM 500 Ex	120	250 <sup>1</sup>	80,5
DiM 500 Ex	160	<b>200</b> <sup>1</sup>	80,5
DiMR 500 Ex	5 – 40	<b>200</b>	80,5
DiM 1000 Ex	5 – 50	500 <sup>1</sup>	90,5
DiM 1000 Ex	80	<b>400</b> <sup>1</sup>	90,5
DiMR 1000 Ex	5 + 10	500	90,5
DiM 2000 Ex	40 – 80	1000	220
DiM 2000 <sup>2</sup> Ex	160	300	220
DPiM 30 Ex	8 – 60	15	24
DPiM 59 Ex	8 – 60	30	24
DPiM(R) 75 Ex	8 – 34	33,5	38
DPiM 119 Ex	8 – 60	60	24
DPiM(R) 150 Ex	8 – 34	75	38
DPiM(R) 299 Ex	8 – 34	150	38
DPiM(R) 300 Ex	8 – 34	150	40
DPiM 319 Ex	8 – 60	160	39
DPiM(R) 450 Ex	8 – 34	225	40
DPiM(R) 600 Ex	8 – 68	300	46
DPiM 799 Ex	8 – 60	400	39

<sup>1</sup>For these actuators the heating of the gear exceeds that of the motor. The heating of the gear is not detected by the actuator. Do not exceed modulating torques and operation modes.

<sup>2</sup>The maximum torque for this actuator is limited to 1000 Nm

Type of actuator	Output drive speed / operating time	Maximum modulating torque	Average weight in kg
DPiM(R) 900 Ex	8 – 68	450	46
DPiM 1200 Ex	7 – 75	600	51
DPiM(R) 1200 Ex	18 – 75	600	51
DPiM 1599 Ex	8 – 60	800	48
DPiM 1800 Ex	7 – 75	900	51
DPiM(R) 1800 Ex	18 – 75	900	51

Table 9.2: Technical data



**DANGER**  
**Excessive temperature when exceeding the max. permissible modulating torque (Explosion hazard!)**

- Make sure that the modulating torque of the valve does not exceed 50 % of the maximum permissible torque of the actuator, if not indicated otherwise in table 9.2.

## 9.4 Types of duty for different versions

The actuator duty should be adhered to, even if the operation times from open to close exceed the limit of the operating time. The type of duty depends upon the temperature range on the actuator name plates. Type of duty S2–xx min (short-time duty) for multi-turn actuators and S4–xx % on time (periodic intermittent duty with influence on starting procedure) for modulating actuators are to be considered.

With S2 duty rating, the maximum operating time of the actuator is indicated. After this time, the actuator must go in pause mode until cooling down to ambient temperature +2 K. With S4 duty rating, the on time value indicates the permitted running time with reference to the switching cycle. A switching cycle is defined as time between actuator start and next start (sum of actuator running time and pause time).

In general, modulating actuators are always limited to 1,200 switching operation per hour (indicated as c/h on the name plate) (with reversing contactors to 300 c/h)(refer to EN 60034-1). Multi-turn actuators are limited to max. S2–15 min.



**DANGER**  
**Danger of sparks (Explosion hazard!)**

- When selecting the adapted moving elements of valves in combination with the output drive of the actuator, make sure that the material pairs are not subject to potential forming of sparks in compliance with EN 13463-5 (e.g. bronze/steel, aluminium/steel, cast iron/steel...).

**DANGER**  
**Excessive temperature when exceeding the max. permissible number of starts (Explosion hazard!)**

- The max. number of starts for modulating applications must not exceed 1200 c/h. Depending on type of actuator and ambient temperature, restrictions with regard to number of starts according to the name plate must imperatively be observed.

**DANGER**  
**Failure to observe specifications (Explosion hazard!)**

- Any restrictions (refer to name plate) applicable for the actuators must be heeded!

**DANGER**  
**Pulling load**

- The following actuators are equipped with an additional brake motor: D1000 output speed 120 rpm and 160 rpm  
D2000 all output speeds.

**For TB motors:**

The brake and the respective wiring is designed as a spring-applied brake. Stopping while pulling loads are active can be guaranteed up to an effective torque at the output drive of 300 Nm.

**For standard motors:**

The brakes of standard motors are generally not designed for stopping pulling loads.

# 10 External warnings

This chapter contains a list of warnings and service advices that have to be placed on the actuator and have to be visible for the lifetime of the actuator. It is not permitted to cover these warnings with paint! All given positions are relative to the viewing direction on the display.



Label with adress of the manufacturer



Label if the actuator is of correspondig type

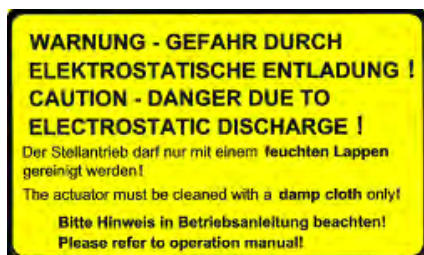

Label with warning for actuators of explosion-proof version



Label with warning of dangerous voltages

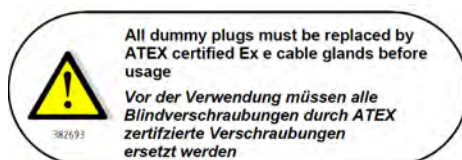

Label with warning for actuators of explosion-proof version ATEX type

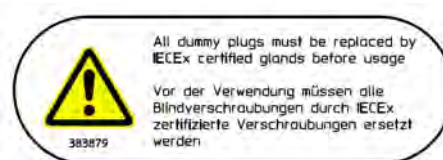

Label with warning for actuators of explosion-proof version IECEx type

# 11 Certificates

The following section contains the Declarations of Conformity and Incorporation, Type Test Certificates as well as additional Certificates for the actuator type range described in these operation instructions if any.



## NOTICE

**The printed Documents are up-to-date to the date of publication of these instructions**

- Please refer to <http://site.drehmo.com/en/downloads> for downloading further supplements to the printed documents.



## EU Declaration of Conformity / Declaration of Incorporation in compliance with Machinery Directive

As the manufacturer DREHMO GmbH hereby declare that electro-mechanical DREHMO® actuators and accompanying components from the following series:

**i-Matic**

**DiM(R) 30 Ex - DiM(R) 2000 Ex**  
**DPiM(R) 30 Ex - DPiM(R) 1800 Ex**

comply with the fundamental requirements of the ATEX Directive (2014/34/EU), the Electromagnetic Compatibility Directive (2014/30/EU), the Low Voltage Directive (2014/35/EU) and the Machinery Directive (2006/42/EC).

EU Declaration of Conformity according to the Council Directive on the approximation of laws of the member states relating to the ATEX Directive (2014/34/EU), the Electromagnetic Compatibility Directive (2014/30/EU) and the Low Voltage Directive (2014/35/EU).

Notified body: TÜV SÜD Product Service GmbH - Zertifizierstelle -  
Identification number: 0123  
Address: TÜV SÜD Ridlerstraße 65; 80339 München  
Certification number: TPS 17 ATEX Q 78524 004  
Type approval test certificates: PTB 07 ATEX 1038 X

The following harmonised standards in terms of the specified directives have been applied:

ATEX Directive (2014/34/EU)  
EN 60079-0:2012+A11:2013 EN 60079-1:2014  
EN 60079-7:2015 EN 60079-31:2014  
EN 13463-1:2009 EN 13463-5:2011  
EN 1127-1:2011

Electromagnetic Compatibility Directive (2014/30/EU)  
EN 61000-6-2:2005 EN 61000-6-4:2007+A1:2011  
EN 61000-3-2:2006+A1,A2:2009 EN 61000-3-11:2000

Low Voltage Directive (2014/35/EU)  
EN 61010-1:2010 EN 60034-1:2010

Declaration of Incorporation in terms of EC Machinery Directive (2006/42/EC) Appendix II B

The following harmonised standards in terms of the Machinery Directive (2006/42/EC) have been applied:

EN ISO 12100:2010

DREHMO® actuators are intended for assembly with valves. The commissioning phase should only be implemented if it has been ensured that the final machinery in which the DREHMO® actuators are installed complies with the regulations of the EC Machinery Directive (2006/42/EC). DREHMO® as manufacturer declares herewith, that the above mentioned linear thrust units meet the following basic requirements of the EC Machinery Directive (2006/42/EC):

Appendix I, articles: 1.1.2, 1.1.3, 1.1.5, 1.2.1, 1.2.6, 1.3.1, 1.3.7, 1.5.1, 1.6.3, 1.7.1, 1.7.3, 1.7.4  
The manufacturer is obliged to electronically submit the documents for the partly completed machinery to national authorities on request. The relevant technical documents pertaining to the machinery according to Appendix VII part B have been complied.

Person responsible for documentation:

Dr. Rüdiger Stenzel, Zum Eichstruck 10, 57482 Wenden/Germany

Wenden, 2018-03-02

W. Händel, General Manager



(1) **EU-TYPE-EXAMINATION CERTIFICATE**  
(Translation)

(2) Equipment or Protective Systems Intended for Use in  
Potentially Explosive Atmospheres - **Directive 2014/34/EU**

(3) EU-Type Examination Certificate Number:

**PTB 07 ATEX 1038 X**

**Issue: 01**

(4) Product: Actuator type D\*iM\*\*-\*-\* Ex

(5) Manufacturer: Drehmo GmbH

(6) Address: Zum Eichstruck 10, 57482 Wenden, Germany

(7) This product and any acceptable variation thereto is specified in the schedule to this certificate and the documents therein referred to.

(8) The Physikalisch-Technische Bundesanstalt, notified body No. 0102 in accordance with Article 17 of the Directive 2014/34/EU of the European Parliament and of the Council, dated 26 February 2014, certifies that this product has been found to comply with the Essential Health and Safety Requirements relating to the design and construction of products intended for use in potentially explosive atmospheres, given in Annex II to the Directive.

The examination and test results are recorded in the confidential Test Report PTB Ex 18-17182.

(9) Compliance with the Essential Health and Safety Requirements has been assured by compliance with:  
**EN 60079-0:2012+A11:2013, EN 60079-1:2014, EN 60079-7:2015, EN 60079-31:2014**

(10) If the sign "X" is placed after the certificate number, it indicates that the product is subject to the Specific Conditions of Use specified in the schedule to this certificate.

(11) This EU-Type Examination Certificate relates only to the design and construction of the specified product in accordance to the Directive 2014/34/EU. Further requirements of the Directive apply to the manufacturing process and supply of this product. These are not covered by this certificate.

(12) The marking of the product shall include the following:

 **II 2 G Ex db eb IIC T4 Gb or Ex db eb IIB T3 Gb**  
 **II 2 D Ex tb IIIC T130°C Db**

Konformitätsbewertungsstelle, Sektor Explosionsschutz

Braunschweig, January 22, 2018

On behalf of PTB

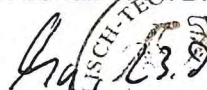
  
Dr.-Ing. D. Markus  
Oberregierungsrat



(13)

## SCHEDULE

(14) **EU-Type Examination Certificate Number PTB 07 ATEX 1038 X, Issue: 01**

(15) Description of Product

The actuator, type D\*\*\*\*-.\* Ex, consists of the following components:

- Enclosure accommodating a planetary gear. For part-turn actuators an additional planetary gear "SQ". Optionally mounted valve attachment. The planetary gears and the valve attachment are not form part of this type approval.
- Flange-mounted motor of Flameproof Enclosure "db" type of protection.
- Optionally flange-mounted – separately certified – motor of Flameproof Enclosure "db" type of protection or Increased Safety "eb" type of protection.
- Motor terminal compartment of Increased Safety "eb" type of protection cast to the enclosure, with – separately certified – terminals. It is connected to the motor and the electronics compartment by means of – separately certified – wire bushings.
- An electronics compartment of Flameproof Enclosure "db" type of protection cast to the enclosure, provided with an inspection window.
- A terminal box of Increased Safety "e" type of protection, with – separately certified – terminals.
- Optionally a – separately certified - plug connector type KP, KPH and KES (DEKRA 11 ATEX 0008X) of Increased Safety "e" type of protection.
- Optionally a - separately certified - terminal compartment type KES-Exd in the type of protection flameproof enclosure "d" (DEKRA 11 ATEX 0008X).
- Optionally a - separately certified - plug connector type K.Exe and K.Exd (DEKRA 17 ATEX 0033U) in the types of protection Increased Safety "eb" and Flameproof Enclosure "db".
- Optionally an external control system. The control system may be outside the potentially explosive area (no ex-protection) or in an explosion protected design, inside the potentially explosive area. The electronics compartment of the actuator in the type of protection Flameproof Enclosure will in this case be filled with packing material.

sheet 2/4

**SCHEDULE TO EU-TYPE EXAMINATION CERTIFICATE PTB 07 ATEX 1038 X, Issue: 01**

Technical data

Rated voltage	up to 690 V
Rated current	max. 27 A *)
Rated cross section	max. 16 mm <sup>2</sup>
Ambient temperatures	-25 °C to +40 °C (standard) -30 °C to +40 °C (IIC, T4) -30 °C to +60 °C (IIC, T4) -55 °C to +40 °C (IIC, T4 with heater) -30 °C to +65 °C (IIB, T3)
Ingress protection	IP66 in accordance with EN 60529

\*) may be higher for separately certified motors

The electrical data are based on the connected motor as well as the electric components accommodated in the electronics compartment.

Nomenclature

D	*	iM*	*	*	-	*	-	*		Ex
1	2	3	4	5	6	7	8	9	10	11

Position	Range of values	Significance
1	D	DREHMO actuator
2		Multi-turn actuator
	P	Part-turn actuator
3	iM	Actuator with i-matic or i-matic C controls
4		Actuator for open-close operation, type of duty S2
	R	Actuator for modulating operation, type of duty S4
5	30 to 2000	Tripping torque in Nm for multi-turn actuator
	75 to 1800	Tripping torque in Nm for part-turn actuator
6	-	Dash
7		Without valve attachment (output drive)
	A, AF, B, B1, B2, B3, B3DO, B4, C, D, DO, DOU, DSTO, DSTU, E, EDO, ...	Valve attachment for multi-turn actuators according to EN ISO 5210
	B, V, W, L/D, H, FH, FW, ...	Valve attachment for part-turn actuators according to EN ISO 5211
8	-	Dash
9	5 to 160 (50Hz)	Output speed in rpm (Multi-turn)
	6 to 192 (60Hz)	
	7 to 75 (50HZ)	Operating time for 90° in seconds (Part-turn)
	6 to 63 (60Hz)	
10		Blank
11	Ex	Explosion-proof actuator

**SCHEDULE TO EU-TYPE EXAMINATION CERTIFICATE PTB 07 ATEX 1038 X, Issue: 01**

1) The actuator type D. iM\* \*\*\*\*\_\* \*-\*\*\*-Ex has been tested according to the standards EN 60079-0:2012 + A11:2013, EN 60079-1:2014, EN 60079-7:2015 and EN 60079-31:2014. Therefore the marking is changed to:

 II 2 G Ex db eb IIC T4 Gb or Ex db eb IIB T3 Gb

 II 2 D Ex tb IIIC T 130 °C Db

2) The nomenclature has been redesigned.

3) The plug connector type K.Exe and type K.Exd (DEKRA 17 ATEX 0033U) can be optionally used.

(16) Test Report PTB Ex18-17182

(17) Specific conditions of use

Repair and overhaul of the flameproof gaps are only allowed according constructive information given from the original manufacturer. A repair according the values given in Table 1 or Table 2 of IEC 60079-1 is not permitted.

Danger due to electrostatic discharge. The actuator must be cleaned with a damp cloth only. Please refer to operation manual.

(18) Essential health and safety requirements

Met by compliance with the aforementioned standards.

According to Article 41 of Directive 2014/34/EU, EC-type examination certificates which have been issued according to Directive 94/9/EC prior to the date of coming into force of Directive 2014/34/EU (April 20, 2016) may be considered as if they were issued already in compliance with Directive 2014/34/EU. By permission of the European Commission supplements to such EC-type examination certificates and new issues of such certificates may continue to hold the original certificate number issued before April 20, 2016.

Konformitätsbewertungsstelle, Sektor Explosionsschutz

Braunschweig, January 22, 2018

On behalf of PTB:

  
  
Dr.-Ing. D. Markus  
Oberregierungsrat





# IECEX Certificate of Conformity

## INTERNATIONAL ELECTROTECHNICAL COMMISSION IEC Certification Scheme for Explosive Atmospheres

for rules and details of the IECEx Scheme visit [www.iecex.com](http://www.iecex.com)

Certificate No.: IECEx PTB 15.0033X

Issue No: 1

Certificate history:

Issue No. 1 (2018-01-22)

Issue No. 0 (2016-01-19)

Status: **Current**

Page 1 of 5

Date of Issue: **2018-01-22**

Applicant: **DREHMO GmbH**  
Zum Eichstruck 10  
57482 Wenden  
**Germany**

Equipment: **Actuator type D \*\*\*\* - \* - \* Ex**

*Optional accessory:*

Type of Protection: **"d", "e"**

Marking: Ex db eb IIC T4 Gb or Ex db eb IIB T3 Gb

*Approved for issue on behalf of the IECEx  
Certification Body:*

Dr.-Ing. Detlev Markus

*Position:*

Head of Department Explosion Protection in Energy Technology

*Signature:  
(for printed version)*

*Date:*

1. This certificate and schedule may only be reproduced in full.
2. This certificate is not transferable and remains the property of the issuing body.
3. The Status and authenticity of this certificate may be verified by visiting the [Official IECEx Website](http://www.iecex.com).

Certificate issued by:

**Physikalisch-Technische Bundesanstalt (PTB)**  
Bundesallee 100  
38116 Braunschweig  
Germany





# IECEX Certificate of Conformity

Certificate No: IECEX PTB 15.0033X

Issue No: 1

Date of Issue: **2018-01-22**

Page 2 of 5

Manufacturer: **DREHMO GmbH**  
Zum Eichstruck 10  
57482 Wenden  
**Germany**

Additional Manufacturing location(s):

This certificate is issued as verification that a sample(s), representative of production, was assessed and tested and found to comply with the IEC Standard list below and that the manufacturer's quality system, relating to the Ex products covered by this certificate, was assessed and found to comply with the IECEX Quality system requirements. This certificate is granted subject to the conditions as set out in IECEX Scheme Rules, IECEX 02 and Operational Documents as amended.

## STANDARDS:

The apparatus and any acceptable variations to it specified in the schedule of this certificate and the identified documents, was found to comply with the following standards:

**IEC 60079-0 : 2011** Explosive atmospheres - Part 0: General requirements  
Edition:6.0

**IEC 60079-1 : 2014-06** Explosive atmospheres - Part 1: Equipment protection by flameproof enclosures "d"  
Edition:7.0

**IEC 60079-7 : 2015** Explosive atmospheres – Part 7: Equipment protection by increased safety "e"  
Edition:5.0

*This Certificate **does not** indicate compliance with electrical safety and performance requirements other than those expressly included in the Standards listed above.*

## TEST & ASSESSMENT REPORTS:

*A sample(s) of the equipment listed has successfully met the examination and test requirements as recorded in*

Test Report:

[DE/PTB/ExTR15.0038/01](#) [DE/PTB/ExTR15.0041/00](#)

Quality Assessment Report:

[DE/TPS/QAR15.0004/01](#)



# IECEX Certificate of Conformity

Certificate No: IECEx PTB 15.0033X

Issue No: 1

Date of Issue: 2018-01-22

Page 3 of 5

## Schedule

### EQUIPMENT:

*Equipment and systems covered by this certificate are as follows:*

#### Description

The actuator, type D\*\*\*\*-\*. Ex, consists of the following components:

- Enclosure accommodating a planetary gear. The planetary gear does not form part of this type approval. (i-matic and standard)
- Flange-mounted motor of Flameproof Enclosure "db" type of protection. (i-matic and standard)
- Optionally a flange-mounted – separately certified – motor of Flameproof Enclosure "db" type of protection or Increased Safety "eb" type of protection. (i-matic and standard)
- Optionally motor terminal compartment of Increased Safety "eb" type of protection cast to the enclosure, with – separately certified – terminals. It is connected to the motor and the electronics compartment by means of – separately certified – wire bushings. (always on i-matic)
- Optionally an electronics compartment of Flameproof Enclosure "db" type of protection cast to the enclosure, provided with an inspection window. (always on i-matic)
- A terminal box of Increased Safety "e" type of protection, with – separately certified – terminals (i-matic and standard)

#### SPECIFIC CONDITIONS OF USE: YES as shown below:

Repair and overhaul of the flameproof gaps are only allowed according constructive information given from the original manufacturer. A repair according the values given in Table 1 or Table 2 of IEC 60079-1 is not permitted.

Danger due to electrostatic discharge. The actuator must be cleaned with a damp cloth only. Please refer to operation manual.



# IECEX Certificate of Conformity

Certificate No: IECEx PTB 15.0033X

Issue No: 1

Date of Issue: 2018-01-22

Page 4 of 5

## **EQUIPMENT (continued):**

- Optionally a - separately certified - plug connector type KP, KPH and KES in the type of protection Increased Safety "e" (IECEX DEK 12.0022X). (i-matic).

- Optionally a - separately certified - terminal compartment type KES-Exd in the type of protection flameproof enclosure "d" (IECEX DEK 12.0022X). (i-matic).

- Optionally a - separately certified - plug connector type K.Exe and K.Exd in the type of protection Increased Safety "eb" and Flameproof Enclosure "db" (IECEX DEK 17.0012U).

- Optionally an external control system. The control system may be outside the potentially explosive area (no ex-protection) or in the type of protection Increased Safety "eb" and Flameproof enclosure "db", inside the potentially explosive area. The electronics compartment of the actuator of Flameproof Enclosure type of protection will in this case be filled with packing material. (i-matic).

Technical data and Nomenclature see Annex.



# IECEX Certificate of Conformity

Certificate No: IECEx PTB 15.0033X

Issue No: 1

Date of Issue: 2018-01-22

Page 5 of 5

## DETAILS OF CERTIFICATE CHANGES (for issues 1 and above):

- 1) New test according to IEC 60079-7:2015.
- 2) The - separately certified - plug connector type K.Exe and K.Exd in the type of protection Increased Safety "eb" resp. Flameproof Enclosure "db" (IECEX DEK 17.0012U) is supplemented.

## Annex:

[COCA15.0033X-Issue1.pdf](#)



Applicant: DREHMO GmbH  
Zum Eichstruck 10  
57482 Wenden  
Germany

Electrical Apparatus: Actuator type D\*\*\*\*-\*-\* Ex

### Technical data

Rated voltage	up to 690 V
Rated current	max. 27 A *)
Rated cross section	max. 16 mm <sup>2</sup>
Ambient temperatures	-25 °C to +40 °C (standard) -30 °C to +40 °C (IIC, T4) -30 °C to +60 °C (IIC, T4) -55 °C to +40 °C (IIC, T4 with heater) -30 °C to +65 °C (IIB, T3)
Ingress protection	IP66 in accordance with EN 60529
*) may be higher for separately certified motors	

The electrical data are based on the connected motor as well as the electric components accommodated in the electronics compartment.

### Nomenclature

D	*	*	*	*	-	*	-	*		Ex
1	2	3	4	5	6	7	8	9	10	11

Position	Range of values	Significance
1	D	DREHMO actuator
2		Multi-turn actuator
	P	Part-turn actuator
3		Actuator without control unit (standard)
	iM	Actuator with i-matic or i-matic C controls
4		Actuator for open-close operation, type of duty S2
	R	Actuator for modulating operation, type of duty S4
5	30 to 2000	Tripping torque in Nm for multi-turn actuator
	75 to 1800	Tripping torque in Nm for part-turn actuator
6	-	Dash
7		Without valve attachment (output drive)



	A, AF, B, B1, B2, B3, B3DO, B4, C, D, DO, DOU, DSTO, DSTU, E, EDO, ...	Valve attachment for multi-turn actuators according to EN ISO 5210
	B, V, W, L/D, H, FH, FW, ...	Valve attachment for part-turn actuators according to EN ISO 5211
8	-	Dash
9	5 to 160 (50Hz)	Output speed in rpm (Multi-turn)
	6 to 192 (60Hz)	
	7 to 75 (50HZ)	Operating time for 90° in seconds (Part-turn)
	6 to 63 (60Hz)	
10		Blank
11	Ex	Explosion-proof actuator

# **DREHMO**

## **VALVE ACTUATORS**

**A member of the AUMA Group**



**DREHMO GmbH**  
**Zum Eichstruck 10**  
**57482 Wenden/Germany**  
**Phone: +49 2762 9850-0**  
**Phone service: +49 2762 9850-204**

**Internet: [www.drehmo.com](http://www.drehmo.com)**  
**E-mail: [drehmo@drehmo.com](mailto:drehmo@drehmo.com)**