

HIGH PERFORMANCE BUTTERFLY VALVE HP 111-E



Wafer type butterfly valve in double-eccentric construction. Reliable sealing even with extreme temperature and pressure conditions.

TECHNICAL DATA

Nominal diameter:	DN 50 - DN 200 (larger nominal diameter on request)
Face-to-face:	EN 558 Series 20 ISO 5752 Series 20 API 609 Table 1
Flange accommodation:	EN 1092 PN 10/16 ASME Class 150 AS 4087 PN16/21
Flange Surface Design:	EN 1092, Form A/B, ASME RF,FF
Top flange:	EN ISO 5211
Marking:	EN 19
Tightness check	Independent of flow-direction
- for R-PTFE seat:	EN 12266 (Leakage rate A)
- for Inconel seat:	EN 12266 (Leakage rate B) ISO 5208, Category 3
Temperature range:	-10°C to +450°C
Differential pressure:	see pressure/ temperature diagram
Vacuum:	up to 1mbar absolute

FEATURES

- Shut-off and control of gaseous and liquid media
- Disc has double-eccentric bearing
- Centering pieces can be used as installation aid
- Two seat ring systems available: R-PTFE and Inconel
- Seat variants:
 - soft seating: (R-PTFE) max. 230°C
 - EBRODUR (UHMWPE), highly non-abrasive, max. 80°C
 - metallic seating: (Inconel) max. 600°C
- Maintenance-free
- Long service life, even at high switching frequencies
- Firesafe API Standard 607 - 7th edition, ISO 10497-5: 2010

GENERAL APPLICATIONS

- Chemical and petrochemical industries
- Hot water and steam systems
- District heat supply
- Vacuum systems
- Shipbuilding
- Gas process technology
- Food industries
- Heavy duty services



The splitted shaft design allows better flow characteristics up to a nominal pressure of 19 bar.

HIGH PERFORMANCE BUTTERFLY VALVE HP 111-E

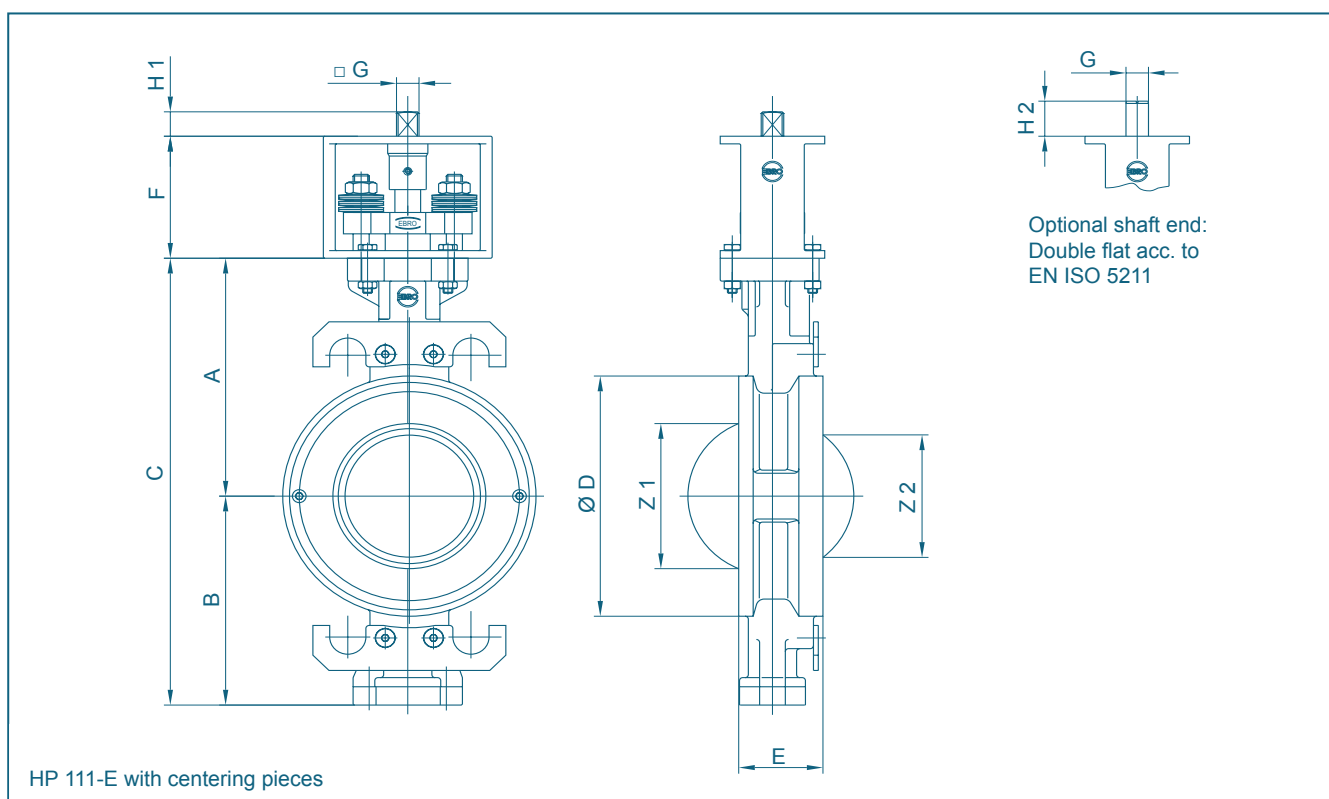

Optional shaft end:
Double flat acc. to
EN ISO 5211

DN [mm]	Size [in]	Dimensions [mm]													min. pipe-Ø	Weight [kg]
		A	B	C	D	E	F	Flange	□G	H1	G	H2	Z1	Z2		
50-65	2-2½	131	112	243	122	43	80	F05/F07	12	15	14	23	41	-	51	6
80	3	141	122	263	138	46	80	F05/F07	12	15	14	23	71	55	80	6
100	4	156	137	293	158	52	80	F05/F07	12	15	14	23	95	82	103	7
125	5	180	172	352	186	56	80	F07/F10	14	18	17	28	115	106	124	11
150	6	194	186	380	216	56	80	F07/F10	14	18	17	28	144	136	151	14
200	8	219	212	431	270	60	80	F10/F12	17	18	22	37	188	182	196	25

*Special face to face

Subject to change without notice

HIGH PERFORMANCE BUTTERFLY VALVE HP 111-E

MATERIAL SPECIFICATION AND PARTS LIST

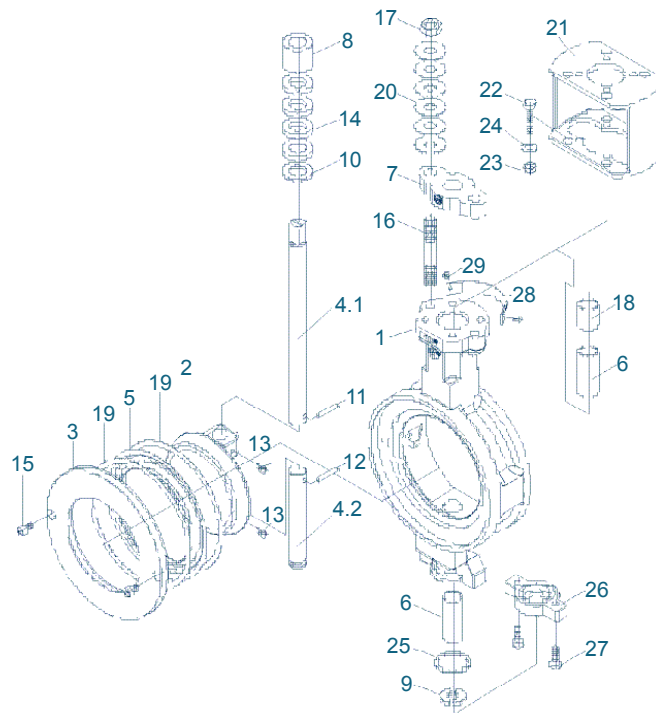

Pt.	Description	Material	Material-No.	ASTM	Pt.	Description	Material	Material-No.	ASTM		
1	Body	Carbon steel	GP240GH (GS-C25N)	1.0619	A216 WCB	13	Set screw	Stainless steel	A4-70	1.4401	A193-B8M
		Stainless steel	G-X5CrNiMo19-11-2	1.4408	A315-CF8M	14	Shaft seal	Graphite			
2	Disc	Stainless steel	G-X5CrNiMo19-11-2	1.4408	CF8M		PTFE				
		St. Steel/nickel-plated	G-X5CrNiMo19-11-2	1.4408	CF8M	15	Hex.-socket screw	Stainless steel	A4-70	1.4401	A193-B8M
3	Clamping ring	Steel	S235JR+N	1.0038+N		16	Threaded pin	Stainless steel	A 2	1.4301	8
		Stainless steel	X5CrNiMo17-12-2	1.4401	A240-316	17	Hex. nut	Stainless steel	A2-70		A194-8
4.1	Upper shaft	Stainless Steel	X4CrNiMo16-5-1	1.4418		18	Spacer sleeve	Stainless steel	X6CrNiMoTi17-12-2	1.4571	A276-316 Ti
		(< 300°C)				19	Graphite seal	Graphite			
4.2	Lower shaft	Stainless Steel	X6NiCrTiMoVB 25-15-2	1.4980		20	Belleville spring washer	Stainless steel	51CrV4	1.8159	A829M
		(> 300°C)				21	Bracket	Stainless steel	GX5CrNiMo19-11-2	1.4408	A351-CF8M
5	Seat ring	R-PTFE	PTFE-Compound			22	Hex. bolt	Stainless steel	A2-70		A193-B8 / B8T
		Inconel	Inconel 625			23	Hex. nut	Stainless steel	A2-70		A194-8 / 8T
6	Shaft bearing	Stainless steel nitrite	X6CrNiMoTi17-12-2	1.4571 nitrite	A276-316 Ti	24	Washer	Stainless steel	A2		
		Stainless steel PTFE	X5CrNi18-10	1.4301/PTFE	A240-304	25	Seal	Graphite			
7	Gland flange	Stainless steel	G-X5CrNiMo19-11-2	1.4408	A315-CF8M		PTFE				
		Stainless steel	X6CrNiMoTi17-12-2	1.4571	A276-316 Ti	26	Cover plate	Stainless steel	GX5CrNiMo19-11-2	1.4408	A351-CF8M
9	Segments	Stainless steel nitrite	X6CrNiMoTi17-12-2	1.4571 nitrite	316 Ti	27	Hex.-socket screw	Stainless steel	A2-70		A193-B8 / B8T
		Stainless steel	X6CrNiMoTi17-12-2	1.4571	316 Ti	28	Name plate	Stainless steel			
10	Suppor. washer	Stainless steel	X4CrNiMo16-5-1	1.4418		29	Groove pin	Other materials upon request			
		Stainless steel	X6CrNiMoTi17-12-2	1.4571	A276-316 Ti						
11	Upper pin	Stainless steel	X4CrNiMo16-5-1	1.4418							
		Stainless steel	X4CrNiMo16-5-1	1.4418							
12	Lower pin	Stainless steel	X4CrNiMo16-5-1	1.4418							
		Stainless steel	X4CrNiMo16-5-1	1.4418							

Subject to change without notice

HIGH PERFORMANCE BUTTERFLY VALVE HP 111-E

TORQUE

- The values specified are based on the initial breakaway torque. (disc disengages from seat, torque then drops)

DN [mm]	Size [in]	Operating pressure			
		10 [bar]		16 [bar]	
		R-PTFE	Inconel	R-PTFE	Inconel
50-65	2-2½	27	35	28	42
80	3	28	55	30	65
100	4	51	90	61	100
125	5	63	150	83	172
150	6	125	170	136	220
200	8	205	350	260	430

All values in Nm

PRESSURE/TEMPERATURE DIAGRAM

----- Pressure control line for GS-C25 body material and metal seat

— Pressure control line for 1.4408 body material and metal seat

----- Pressure control line for R-PTFE

The diagram illustrates the performance of the standard version of our valve type HP. Valves for higher pressure or deviating temperature are available upon request.

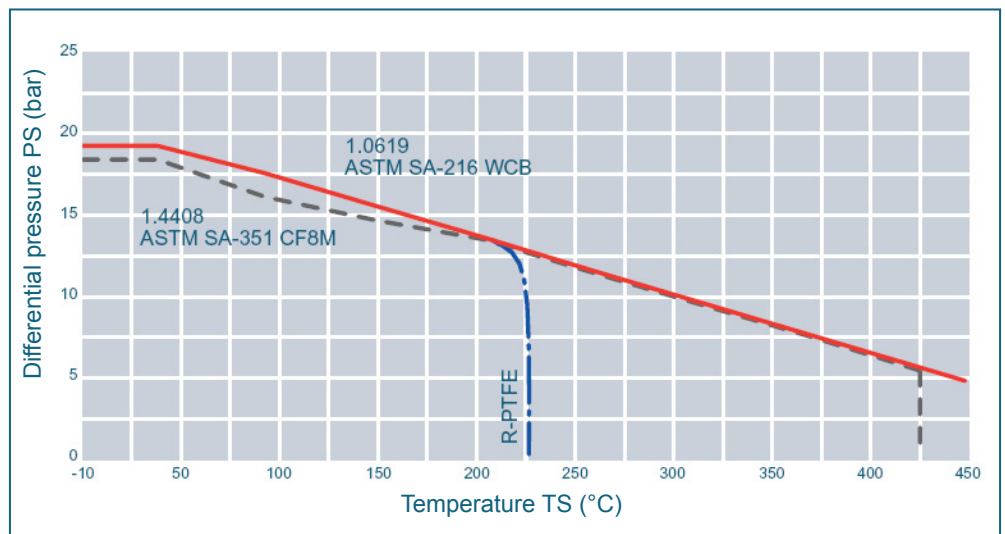

K_v-VALUES

- The K_v-value [m³ per hour] is the flow of water at a temperature of 5°C to 30°C (41°F to 86°F) at Δp of 1 bar

- The K_v-values specified are based on tests carried out by the Delfter Hydraulics Laboratories, the Netherlands

- Permissible velocity of flow
V_{max} 4,5 m/s for liquids,
V_{max} 70 m/s for gases

For further values, please contact our engineers.

DN [mm]	Size [in]	Opening angle α°							
		20°	30°	40°	50°	60°	70°	80°	90°
50-65	2-2½	3	13	28	39	49	58	69	81
80	3	19	40	63	96	135	189	242	287
100	4	33	65	89	125	180	259	365	450
125	5	53	105	169	245	342	509	645	728
150	6	82	161	252	385	575	817	1010	1123
200	8	105	184	331	559	816	1217	1795	1921

Subject to change without notice