

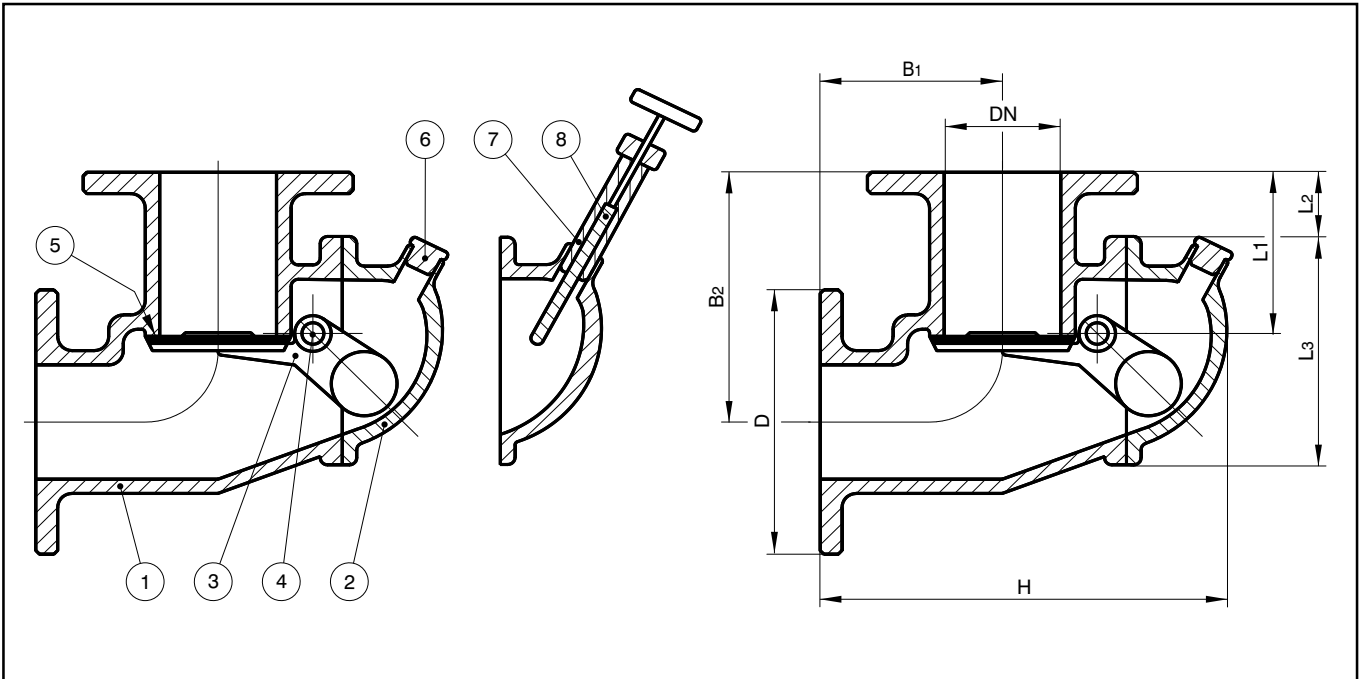

Stormklapventil  
Storm valve  
Sturmklappe

AT  
TYPE PHH 596

DN 40 - DN 150  
Flangetilslutning PN 10



Pos.	Komponent	Materiale	Part	Material	Teil	Werkstoffe
1	Hus	Rødgods Rg 5	Body	B.S.1400:1961 LG 2-C	Gehäuse	G-CuSn5 PbZn
2	Dæksel	Rødgods Rg 5	Cover	B.S.1400:1961 LG 2-C	Deckel	G-CuSn5 PbZn
3	Klap	Rødgods Rg 5	Flap	B.S.1400:1961 LG 2-C	Klappe	G-CuSn5 PbZn
4	Aksel	Specialmessing	Axel	Special brass	Welle	Sondermessing
5	Pakning	NBR	Sealing	NBR	Dichtung	NBR
6	Prop	Specialmessing	Plug	Special brass	Stopfen	Sondermessing
Med spærreanordning		With locking device		Mit Feststellvorrichtung		
7	Gevindprop	SM 2065	Thread plug	SM 2065	Gewindestopfen	SM 2065
8	Spindel	SM 2065	Stem	SM 2065	Spindel	SM 2065

DN	Trykklasse Pressure class Drückstufen	D	B <sub>1</sub>	B <sub>2</sub>	H	L <sub>1</sub>	L <sub>2</sub>	L <sub>3</sub>	Vægt Weight Gewicht kg	Max. temp. Max. temp. Max. temp. °C	Prøvetryk [bar] Test pressure [bar] Prüfdruck [bar]	
	PN										Åben (vand) Open (water) Offen (Wasser)	Lukket (luft) Closed (air) Geschlossen (Luft)
40	1	150	90	135	200	72	28	100	10	80	5	2
50	1	165	90	145	210	89	34	130	13	80	5	2
65	1	185	109	165	242	104	38	155	17	80	5	2
80	1	200	115	190	260	119	40	187	23	80	5	2
100	1	220	125	215	290	134	43	207	34	80	5	2
125	1	250	130	250	336	154	53	239	40	80	5	2
150	1	285	160	275	390	154	60	300	63	80	5	2

Ret til ændringer forbeholdes. 10.2004

